

YES, I BOUNCE!



**TOP PHOTOGRAPHERS SECRETS - LIGHT ENHANCED BY CALIFORNIA SUNBOUNCE®**

SUNBOUNCE GmbH • Siems Twieten 4 • 21376 Garlstorf – Germany • Phone: +49 (4172) 987 87 87

Fax: +49 (4172) 987 87 67 • e-mail: [info@sunbounce.com](mailto:info@sunbounce.com) • [www.sunbounce.com](http://www.sunbounce.com)



**THE STORY OF CALIFORNIA SUNBOUNCE®**

Peter Geller was born in Hamburg, Germany. While going to boarding school in his teen years, he was able to earn some extra money by shooting portraits with his first camera. Since he had no strobe lighting he got the idea to use mirrors to reflect the sunlight onto his subjects. After high school, with law school calling him to become a famous lawyer, he took his photo skills with him as a way to make some extra money. His first part time job was as a stringer for the Hamburg Newspaper ABENDBLATT and then STERN magazine as a press photographer.

WOLFGANG-PETER GELLER – Owner of SUNBOUNCE GmbH and SUN-SNIPER GmbH.  
Two time winner of WORLD PRESS PHOTO Award

**WORLD PRESS PHOTO AWARD**

Peter Geller's breakthrough came when he was assigned to cover the breaking story of a bank robbery in the south of Germany. His images were published by all the major magazines around the world. For these amazing shots Peter received the WORLD PRESS PHOTO AWARD in 1971.



Photo: Antje Sievert

NICK UT, winner 1972  
WOLFGANG PETER GELLER, Winner 1971



"WORLD PRESS PHOTO" contest winners meet in Amsterdam  
The winning photos

From then on Peter worked for all major papers and advertising companies. Companies such as KODAK, AGFA, ZEISS, BAYER Pharmaceuticals, and POLAROID were his new clients. For many years he also shot 10,000 covers for Harlequin Romances.

**WINDY JOB IN L.A.**

On this assignment Peter had been shooting in Los Angeles for AGFA Film. With three AGFA clients from Germany, three models from Paris and a crew of four from Hamburg they found themselves stuck in a freak storm in California. As the clouds went away, they left beautiful brilliant sunshine, but also gale force winds on the beach where they were to shoot. Peter had to improvise on the spot. He found that all reflectors were too wobbly in the wind, the shiny boards used by the movie industry were too heavy, and he did not want to hire a set of Grip people just to stand around as human tripods for the reflectors, which he needed for the shoot. So, in his hotel room during downtime, the first prototype SUNBOUNCE was born and worked adequately enough to get the job done. With this success Peter set out to redesign his prototype and came up with the CALIFORNIA SUNBOUNCE® (named for where it was born) SUN-BOUNCE PRO reflector which he patented worldwide. The rest can be seen in this little catalog.



Wolfgang-Peter Geller with the Maharaja of Jodhpur, India



Her Highness Princess Maya Laxmi Devi Rana in Patan, Nepal



*"YES, I BOUNCE!"*



Greg Gorman - Celebrity Photographer  
[www.gormanphotography.com](http://www.gormanphotography.com)

*"THE CALIFORNIA SUNBOUNCE® SYSTEM IS ONE OF THE BEST LOCATION AS WELL AS STUDIO LIGHTING TOOLS, THAT I HAVE EVER WORKED WITH. IT IS FAST, RELIABLE AND COMPACT, GIVING ME THE QUALITY OF LIGHT NEEDED FOR MY SHOTS. I CAN NOW GO ON THE ROAD WITH A LIGHTING SOLUTION THAT MEETS ALL MY NEEDS AND IS EASILY TRANSPORTABLE. WHAT ELSE COULD I ASK FOR?"*

Greg Gorman

Want to learn more?  
Please check for the „MAKING OF VIDEO“ at  
[www.SUNBOUNCE.com](http://www.SUNBOUNCE.com)

*"YES, I BOUNCE!"* SUN-BOUNCE PRO and MINI ZEBRA and SUN-SWATTER PRO -2/3



*"YES, I BOUNCE!"* **SUN-BOUNCE MICRO-MINI ZEBRA and SUN-BOUNCE PRO ZEBRA**

6

Photo: Robin Hinsch



Photo: Robin Hinsch

**SUN-BOUNCE PRO BLACK and MINI ZEBRA and MICRO-MINI ZEBRA  
SUN-BOUNCE MICRO-MINI ZEBRA and SUN-BOUNCE PRO ZEBRA**

Photo: Robin Hinsch

7



"YES, I BOUNCE!"

Steve Thornton

[www.stevethornton.com](http://www.stevethornton.com)



"I AM NOT SURPRISED HOW CALIFORNIA SUNBOUNCE® DRAMATICALLY IMPROVED MY PRODUCTIVITY. OVERALL DURING MY 25+ YEAR CAREER THERE ARE PRECIOUS FEW PHOTOGRAPHIC PRODUCTS I HAVE BOUGHT THAT MORE THAN LIVE UP TO ITS HYPE, THIS IS ONE OF THE VERY FEW."

Steve Thornton

Want to learn more?  
Please check for the „MAKING OF VIDEO“ at  
[www.SUNBOUNCE.com](http://www.SUNBOUNCE.com)

"YES, I BOUNCE!" SUN-BOUNCE MINI SILVER with SUN-BOUNCE PRO SILVER

FLASH-BRACKET and strobe

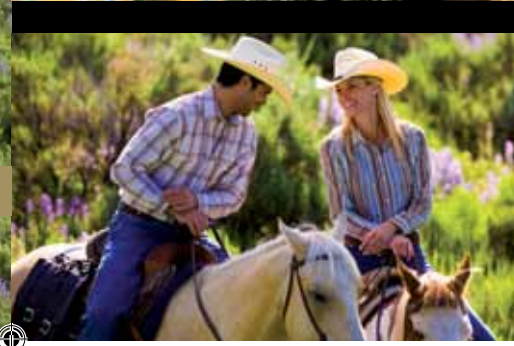

*"YES, I BOUNCE!"* SUN -SWATTER BIG -2/3 f: stop with BOOM-STICK

10

11



*"YES, I BOUNCE!"* SUN-SWATTER PRO -2/3 f: stop and SUN-BOUNCE PRO

SILVER and strobe with lightbox

Want to learn more?  
Please check for the „MAKING OF VIDEO“ at  
[www.SUNBOUNCE.com](http://www.SUNBOUNCE.com)

*"YES, I BOUNCE!"*

Michael Grecco,

Celebrity and Advertising Photographer

[www.michaelgrecco.com](http://www.michaelgrecco.com)



*"SUNBOUNCE GIVES ME THE OPPORTUNITY TO CONTROL THE SUN LIGHT AND USE IT THE WAY I WANT IT, WHEREVER, AND WHATEVER TIME OF DAY IT IS."*

Michael Grecco





*"YES, I BOUNCE!"* above: **SUN-SCRIM LE LOUCHE 8' x 8'** (visible next page)

below: **SUN-BOUNCE PRO ZEBRA**, right: **SUN-BOUNCE MINI ZEBRA**

Shot at David Meceys "FotoFantasyCamp".



*"YES, I BOUNCE!"*



## David Mecey

20 years + Playboy, Fashion-Beauty Photographer  
[www.davidmecey.com](http://www.davidmecey.com)

*"THANK YOU FOR YOUR GREAT LIGHT-MODULATING PRODUCTS THAT MAKE MY JOB EASIER, ESPECIALLY WHEN DELIVERING AN IMPORTANT PHOTO ASSIGNMENT."*  
David Mecey

Want to learn more?  
Please check for the "MAKING OF VIDEO" at  
[www.SUNBOUNCE.com](http://www.SUNBOUNCE.com)



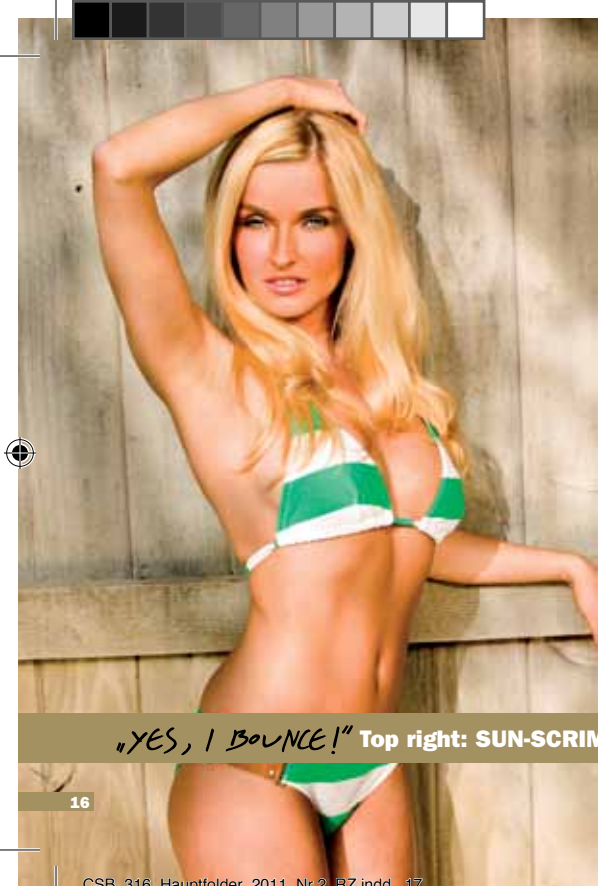

*"YES, I BOUNCE!"* Top right: SUN-SCRIM LE LOUCHE 8' x 8'



Photo: André Boeck



"YOUR CALIFORNIA SUNBOUNCE® PRODUCTS ARE THE BEST AVAILABLE. THEY ARE LIGHT, STRONG AND EXTREMELY EASY TO TRANSPORT. IT IS THE ULTIMATE IN A RIGID SYSTEM THAT WORKS PERFECTLY ON LOCATION OR IN THE STUDIO. WITH THE ADDITION OF THE SUN-SWATTER, YOU CONTINUE TO LEAD THE FIELD WITH YOUR INNOVATIVE LIGHTING REFLECTOR DESIGNS."

David Mecy

Photo: André Boeck



*"YES, I BOUNCE!"* MICRO-MINI ZEBRA and SUN-BOUNCE FLASH-BRACKET

18

*"YES, I BOUNCE!"*

**Mike Larson** - Wedding Photographer  
Mike Larson photography, Inc., [mikelarsonphoto.com](http://mikelarsonphoto.com)

*"PETER, YOUR SUNBOUNCE PRODUCTS MAKE MY IMAGES AND SEPARATE ME FROM THE REST. WHEN IT COMES DOWN TO LIGHTING IT HAS TO BE PERFECT AND AMAZING EVERY TIME. THE SUNBOUNCE IS BETTER THAN ANY OTHER PRODUCT"*

Mike Larson

Want to learn more? Please check for the „MAKING OF VIDEO“ at [www.SUNBOUNCE.com](http://www.SUNBOUNCE.com)

SUNBOUNCE-enhanced flash

no flash

„on camera“ flash

19



*"YES, I BOUNCE!"* Left: WIND-KILLER PRO and SUN-BOUNCE PRO ZEBRA

SUN-BOUNCE MINI ZEBRA with FLASH-BRACKET  
SUN-BOUNCE PRO ZEBRA and MICRO-MINI ZEBRA



*"YES, I BOUNCE!"*

**Art Brewer**  
Life Style and Sports Photographer, [www.artbrewer.com](http://www.artbrewer.com)

*"PETER, SUNBOUNCE...INSANE! TO HAVE TO USE ANY OTHER SYSTEM, I'D FEEL PRIMITIVE."*

Want to learn more? Please check for the „MAKING OF VIDEO“ at [www.SUNBOUNCE.com](http://www.SUNBOUNCE.com)



*"YES, I BOUNCE!"* **EVERYTHING BOUNCING AND SCRIMMING SUN-BOUNCE**





*"YES, I BOUNCE!"* **SUN-BOUNCE MINI and SUN-SWATTER PRO**

*"YES, I BOUNCE!"*

**Janusz Sikora**

DOP, Director of Photographer, [www.lightextreme.com](http://www.lightextreme.com)



*"THE SYSTEM FOR TODAY'S FILMMAKER!*

*CALIFORNIA SUNBOUNCE®... QUICK, FAST, LIGHTWEIGHT, ACCURATE AND EFFICIENT. IN THE AREA OF ESTHETICS... SUNBOUNCE GOES ONE STEP FURTHER WITH ITS POTENTIAL OF CREATIVE CONTROL... ADJUSTABLE PATTERN - LE LOUCHE MAKES IT AN INVALUABLE TOOL IN TURNING BARE SUNLIGHT INTO A PLEASING ENVIRONMENT OF HIGHLIGHT AND SHADOW. ONE-MAN STICK-POLE OPERATION OF OVERHEAD DIFFUSER MAKES IT VERY USEFUL IN CONTRAST CONTROL OF ACTORS MOVEMENT TOWARDS OR AWAY FROM CAMERA.... SURPRISING IS THE LONG THROW OF THE SUNBOUNCE... ALWAYS AN ISSUE WITH OTHER FOLDING REFLECTORS. IN FAST PACED STYLE OF INDEPENDENT FILMMAKING - CALIFORNIA SUNBOUNCE® IS THE SYSTEM FOR TODAY'S FILMMAKER."*

Janusz Sikora



Winner of: Chicago International Film Festival - Gold Plaque in Cinematography. Professor for Lighting at: USC, New York Film Academy and Light Extreme Workshops, LA



"NO SEAM UP TO 16,5 FEET (500CM) WIDTH? YES! AND ANY LENGTH YOU LIKE!"

"YES, I BOUNCE!"

Franz Lustig

[www.franzlustig.com](http://www.franzlustig.com)



"I USED YOUR BOUNCERS AND SCRIMS ON BOTH MY RECENT FILMS WITH WIM WENDERS "LAND OF PLENTY" AND "DON'T COME KNOCKING" THEY ARE WONDERFUL: LIGHTWEIGHT AND STRONG, PERFECTLY DESIGNED FOR HANDHELD USE AND IN SECONDS COLLAPSIBLE TO TRANSPORTABLE SIZE. EVEN WITH WIND THE SILVER PANEL DOES NOT FLICKER. THE RECTANGULAR SHAPE MAKES BEAUTIFUL EYES! THANK GOD NOT ANOTHER ROUND POP-UP! ALL MY AMERICAN FRIENDS IN THE INDUSTRY JUST CALL YOUR SYSTEM "THE GERMAN BOUNCERS" - THANKS PETER." Franz Lustig, DOP of Wim Wenders

"YES, I BOUNCE!" CUSTOM-MADE SEAMLESS OVERSIZE SCREENS





*"YES, I BOUNCE!"* CUSTOM-MADE SEAMLESS OVERSIZE SCREENS





„YES, I BOUNCE!“ **SUN-BOUNCE PRO ZEBRA and SUN-SWATTER PRO -2/3 f: stop**

30

# „YES, I BOUNCE!“

**Guido Karp**  
 Music Photographer, [www.guidokarp.com](http://www.guidokarp.com)  
 Photo: Jay Spence

„OFF STAGE - NO MATTER WHETHER IN BACKSTAGE SESSIONS, MY PHOTO WORKSHOPS OR OUR PHOTO BEAUTY EVENT „PRINCESS FOR ONE DAY“, I CAN NOT EVEN RECALL SHOOTING A SINGLE IMAGE WITHOUT USING A SUNBOUNCE PRODUCT. TOURING THE WORLD WITH R&N BANDS FOR MORE THAN 25 YEARS, I NEED THE MOST RELIABLE AND RIGID EQUIPMENT POSSIBLE. THE CALIFORNIA SUNBOUNCE® SYSTEM DEFINITELY BELONGS INTO MY TOUR BAG.“

Guido Karp

Want to learn more? Please check for the „MAKING OF VIDEO“ at [www.SUNBOUNCE.com](http://www.SUNBOUNCE.com)

31





*"YES, I BOUNCE!"* 2x SUN-BOUNCE MINI ZEBRA and WIND KILLER PRO

32 Jim Jordan shot with Austin Victoria and Reanna Spaulding for Marie Claire  
Styling: Alex Wood, Makeup Artist: Bren Dixie, Assistance: Jordan O'Dell, Celina Muehlbauer, Sara Rae Kirendoll, Mekena Hunt

Photo: Guido Karp

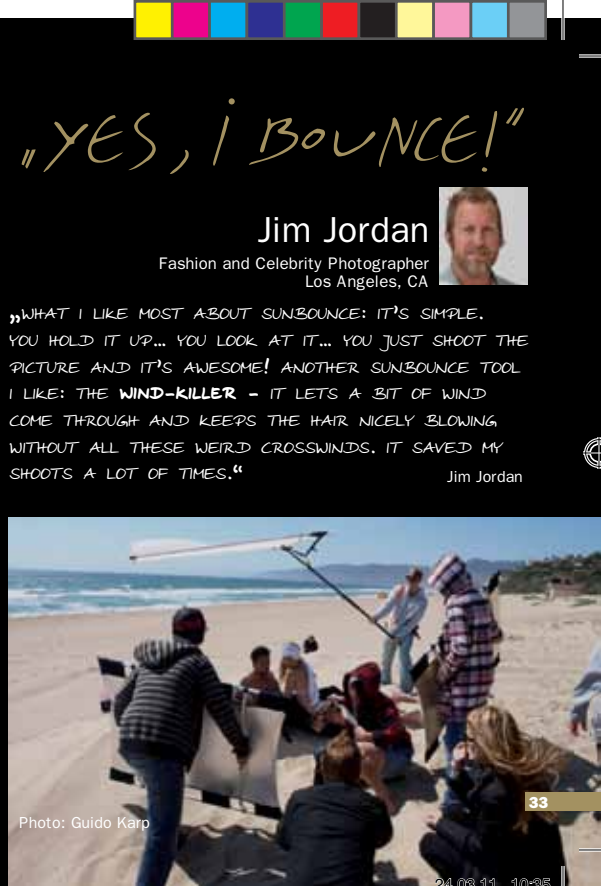

*"YES, I BOUNCE!"*

Jim Jordan

Fashion and Celebrity Photographer  
Los Angeles, CA



„WHAT I LIKE MOST ABOUT SUNBOUNCE: IT'S SIMPLE. YOU HOLD IT UP... YOU LOOK AT IT... YOU JUST SHOOT THE PICTURE AND IT'S AWESOME! ANOTHER SUNBOUNCE TOOL I LIKE: THE WIND-KILLER - IT LETS A BIT OF WIND COME THROUGH AND KEEPS THE HAIR NICELY BLOWING WITHOUT ALL THESE WEIRD CROSSWINDS. IT SAVED MY SHOOTS A LOT OF TIMES.“

Jim Jordan

33

Photo: Guido Karp

## THE SYSTEM: SUN-BOUNCER

### The CALIFORNIA SUNBOUNCE®-SYSTEM

consists of a patented three-dimensional dismantable framework made from finest aluminum. This unique frame works perfectly together with various screens which are reflective, translucent or light-blocking. You can choose from different sizes. The frames are super lightweight, super-strong, and can be broken down to fit into a tube-like bag of about 2 to 3 inches (5-8cm) diameter and a maximum length of about 4 feet (130cm). The CALIFORNIA SUNBOUNCE® system provides you the most perfect lighting tool for any lighting situation.

### THE EXTREME STRENGTH

Stiffness and stability achieved by the patented system and finest aluminum provide precise light output: no dents, no bumps, and no wobble. The synergy of frame and screen gets its super-tension by the permanent elastic screen material used.

### SUPER LIGHTWEIGHT

Weighing less than four pounds (1.800 gr.), the most professional reflector, the PRO saves you a lot of "schlepping". You get more than 22 square feet (2,5 square meter) of stiff reflective or translucent material. The huge panel probably weighs less than your professional camera.

### THE SIMPLE SYSTEM

makes the CALIFORNIA SUNBOUNCE® light-enhancer system always the best tool to use. Whatever you want to shoot, and wherever you need to control your light, the minimal weight and compact breakdown size allow you to take the reflectors anywhere.

## THE SYSTEM: SUN-BOUNCER

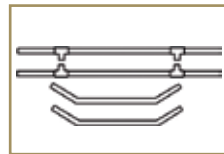

### PARTS:

No part of the frame exceeds 4' 4" (135 cm).

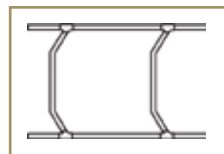

### ASSEMBLY:

Quick and easy set-up provides an extremely strong frame.



### SCREEN / PANEL:

A choice of all necessary panels provides the solution to any light situation.



### READY TO WORK:

In just seconds the synergy of frame and elastic panel provides a drum skin like tension to the system.

## THE SYSTEM: SUN-BOUNCER

### > MEASUREMENTS

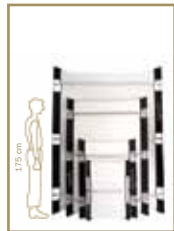

**SUPER LIGHTWEIGHT** of less than 4 pounds (1.800 gr.) for the most professional frame PRO. Saves you a lot of "schlepping". You get more than 22 square feet (2,5 m<sup>2</sup>) of stiff reflective or translucent material. The huge SUN-BOUNCE weighs probably less than your professional camera.



Manual



Mounted



Everything fits into a small shoulder-sling bag.

#### MEASUREMENTS SUN-BOUNCE

MICRO-MINI: 2' x 3' (60 x 90 cm)  
 MINI: 3' x 4' (90 x 125 cm)  
 PRO: 4' x 6' (130 x 190 cm)  
 BIG: 6' x 8' (180 x 245 cm)  
 SUN-STRIP MINI: 4' x 8" (125 x 20 cm)  
 SUN-STRIP PRO: 6' x 8" (190 x 20 cm)

Product dimension, weight or look may change without notice

## THE SYSTEM: SUN-BOUNCER

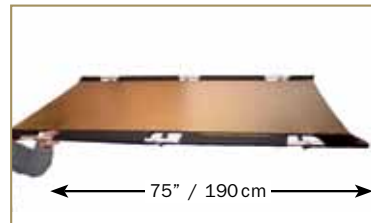

SUN-BOUNCER PRO 75" / 190cm  
 Sturdy as an aircraft

- > **THREE-DIMENSIONAL FRAME**
- > **PERMATENSE TAUGHT SCREEN**
- > **100% PLANE PANEL**
- > **EXTREMELY STRONG, STILL LIGHTWEIGHT**
- > **TINY PACK - HUGE REFLECTOR**



WIND-KILLER PRO  
 as wind-blocker



SUN-BOUNCER PRO  
 as sun-catcher



SUN-BOUNCER PRO  
 as wind-surfer-sail

## THE SYSTEM: SUN-BOUNCER

### SUN-STRIP

Light just where you need it – no disturbing spill light



SUN-STRIP MINI SILVER

SUN-STRIP PRO SILVER



Size of frame:  
SUN-STRIP

projection characteristic  
with ZEBRA

projection characteristic  
with SILVER

projection characteristic  
with WHITE

When the light needs to fall off quickly or when you don't want to spill light all over the room your only choices are: SUN-STRIP MINI or SUN-STRIP PRO.

Two sizes in three colors SILVER/ WHITE and ZEBRA/ WHITE. If you have a spare MINI-FRAME or PRO-FRAME, you only need the upgrade kit, including SCREEN and matching CROSS-BARS

## THE SYSTEM: SUN-BOUNCER

### WIND-KILLER

the WIND-KILLER - it lets a bit of wind come through and keeps the hair nicely blowing without all those weird crosswinds. Excellent for Steadicam operators.



### WIND-KILLER PRO

WIND-KILLER *mobile* PRO (130x190cm) perfect for STEADICAM operators to limit the wind



Both styles are also available in BIG



### WIND-KILLER STATIC

PRO (130x190 cm) or BIG (180x245cm)

## THE SYSTEM: SUN-SWATTER

### The SUN-SWATTER MINI



**SUN-SWATTER MINI and SUN-BOUNCE MINI ZEBRA**

40

## THE SYSTEM: SUN-SWATTER

### The SUN-SWATTER

Like an over-proportioned fly swatter, the **SUN-SWATTER** is a quick and easy “shadow caster” on a pole that has the following advantages to offer:

- It controls the harsh midday sunlight and allows you to work at any time of the day, irrespective of the altitude and direction of the sun.
- Because it controls the sun, the SUN-SWATTER enhances your productivity - you can carry on when others are forced to interrupt their work. This guarantees you a financial advantage of about 3 - 4 hours a day.
- The SUN-SWATTER PRO offers you approximately 22 sq. ft. (2.5 m<sup>2</sup>) and the SUN-SWATTER BIG: 40 sq. ft. (4.5 m<sup>2</sup>) of mobile shadow on a pole. The large shadow can move with the talent, thus enhancing creativity and maintaining the flow of the shoot.



**SUN-SWATTER  
BIG**



**SUN-SWATTER  
PRO**



**SUN-SWATTER  
MINI**

41

## THE SYSTEM: SUN-SWATTER

- The U-shaped frame is open on one side, with no limiting frame shadow on the open end. With a variety of diffusion fabrics, you have a whole range of new possibilities!
- The SUN-SWATTER is really easy to hold and use - even when moving and running with the talents.
- You can instruct anyone on its use within seconds.
- It loves the wind on the beach. If held correctly, it floats with the wind over the heads of your talents.
- Assembly and disassembly is quick and easy.
- Packed away, it is even smaller and lighter than the already feather-light SUN-BOUNCE PRO reflector.
- Change location without moving light stands.
- The SUN-SWATTER enables the fastest possible set-up and location change.
- Thanks to the long BOOM-STICK you have more than enough space for your subject.
- No light stand, no assistant needs to stand near the set and perhaps influence your shot!

### The SUN-SWATTER SPOT



## THE SYSTEM: SUN-SWATTER



SWATTY



The set-up of the SUN-SWATTER PRO and SUN-SWATTER BIG is just a matter of minutes. Easy, lightweight and comfortable. Use the SWATTY to connect the SUN-SWATTER frame to the BOOM-STICK.

The BOOM-SUPPORT makes it completely stress-free to carry the SUN-SWATTER around. For PRO and BIG

SUN-SWATTER: THE BASIS FOR HIGHLY PROFESSIONAL LIGHTING

THE MOST PROFESSIONAL LIGHTING SET-UP



**NAKED SUNLIGHT**

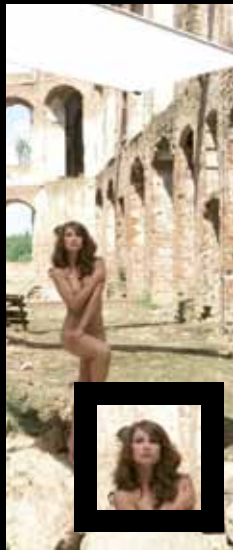

**SWATTED SUNLIGHT**



**SWATTED & BOUNCED SUNLIGHT**

Photos: Robin Hinsch



**SWATTED, BOUNCED & SUBTRACTED SUNLIGHT**

Photo: Robin Hinsch

## THE SYSTEM: SUN-MOVER



46

## THE SYSTEM: SUN-MOVER

The first completely FOCUSABLE flat reflector revolutionizes the world of light formers



**SPOT EFFECT**



When the SUN-MOVER™ is bent inward (the center of the reflector towards the body), it becomes concave and concentrates the light like a SPOT – hard, intense light with minimal dispersion.



**SOFT EFFECT**



When the SUN-MOVER™ is bent outward and becomes convex, the illuminated surface increases. The light is softer and not as intense.



**NEUTRAL EFFECT**



If you simply want to divert the light because it is coming from the wrong direction, place the SUN-MOVER™ in the neutral position.

47



## THE SYSTEM: SUN-MOVER

### The SUN-MOVER

Only at first glance, the SUN-MOVER looks like an ordinary pop-up reflector. But despite the fact that it takes only one hand movement to reduce his size to a third, it does not have anything in common with the simple pop-ups. The patented SUN-MOVER is not round, but elliptical-shaped – this innovative trick guarantees a tightly strained surface and plane reflection face at any time.

The two ergonomically shaped handlebars not only help to achieve perfect control of the light, but also share further characteristics that no other pop-up reflector can provide.

If you bending the face of the SUN-MOVER towards yourself, the light will be bundled like a spotlight. Bend the face of the SUN-MOVER outward creates scattered, soft light. The plane reflection face allows normal light. Thus, the SUN-MOVER system enables the use of three different kinds of light while only using one reflector.

It takes a closer look of professionals before the patented SUN-MOVER system reveals all its opportunities.



## THE SYSTEM: SUN-MOVER

The fantastic original invention by John Russell Ritson of 1977 now with Perma-Tense\* drastically improved by the CALIFORNIA SUNBOUNCE® Design Team.

### LIGHTING AS STRONG AS THE SUN!

This new OVAL designed "permanent-tension" reflector with two-built in handles is a product for greater tautness. "MADE in GERMANY"

GERMAN made spring steel for extra permanent tension

GERMAN elastic hem for even more elasticity

### TWO PLASTIC HANDLES

Increase the permanent tension of the steel frame and helps provide the perfect light control from "full power" down to "tender feathering". Made from environmentally friendly resources

ORIGINAL CALIFORNIA SUNBOUNCE™ ZEBRA/WHITE or SILVER/WHITE material

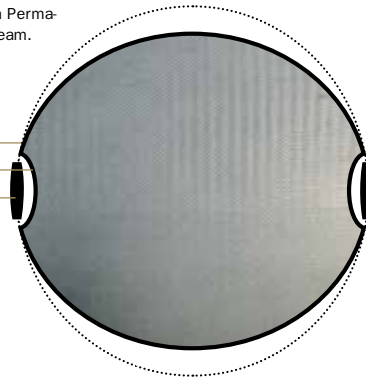

SUN-MOVER silver/ white (seamless)

SUN-MOVER zebra/ white (seamless)

**NEW!**

## THE SYSTEM: FLASH-BRACKET

### MICRO-MINI

The smallest classic Sunbounce reflector. Packed only 60cm (2'). The extension is stacked inside the wider tube. You have to look to find it.



### MICRO-MINI ZEBRA + SILVER



### FLASH-BRACKET



## THE SYSTEM: MICRO-MINI and FLASH-BRACKET



MICRO-MINI + FLASH-BRACKET + BOOM-STICK (+ Speed Light)

## THE SYSTEM: MICRO-MINI and FLASH-BRACKET

### NEW: SUNBOUNCE Flash-Bracket

- For use with the Micro MINI, MINI and PRO BOUNCE Systems
- Once again, California SUNBOUNCE® introduces a new product that we think will change the landscape of reflective panels.
- We all know that the bigger the light source - the better the light looks on the subject. Why have a small pinpoint of light when you can have a wall of light, not unlike the sun?  
The light looks more natural, and covers your subject.
- Thus SUN-BOUNCE has now made the perfect attachment for using your normally "on camera" strobe as a off camera light source.
- As many of today's strobes are wireless, TTL or at least tethered TTL, keeping them totally in sync with the camera is not a problem. The newest wireless flash system attached to the SUN-BOUNCE FLASH-BRACKET and then attached to the stand for a completely hands-free TTL system that will give the user a big, beautiful light source.
- The SUNBOUNCE FLASH-BRACKET clamps to the SUN-BOUNCE frame and can then extend up to 18 inches for use with smaller or bigger SUN-BOUNCE panels.



### MEASUREMENTS:

MICRO MINI: 60x90 cm (2'x3') 550 grams

SUN-BOUNCE FLASH-BRACKET: Ca. 30 cm, extendable to 45 cm for use on MICRO-MINI, MINI or PRO

## THE SYSTEM: MICRO-MINI and FLASH-BRACKET



**MICRO MINI**  
just for sun



**MICRO MINI**  
with one System Flash



**MICRO MINI**  
with two System Flash units



**MICRO MINI**  
Flash units on lightstand

- Be completely mobile with the new light enhancers from CALIFORNIA SUNBOUNCE®. The latest SUNBOUNCE development for SUN- and UNLEASHED Flash System photography SUN-BOUNCE MICRO MINI and SUN-BOUNCE FLASH-BRACKET\*
- Today's DSL-Rs and SUNBOUNCE light enhancers compliment for the perfect MICRO-MINI STUDIO for every light situation

\*can also be used on the MINI and PRO systems



**MICRO-MINI**



an absolute NO,NO,  
mobile copy machine

## THE SYSTEM: SUN-SCRIM



54

## THE SYSTEM: SUN-SCRIM

### > FINEST BLACK-NET MATERIAL: NO MOIRÉ

Single (-1/2 f:stop) or, Double (-1 f:stop)



14 feet wide (440 cm) no seam! It's knitted and can be doubled without producing a moiré (when adjusted 90 degrees to each other).

Our exclusive NO-MOIRÉ is very strong and does not decay. It is made from PP.

55

**CALIFORNIA SUNBOUNCE®**

Diffuser materials -1/3 and -2/3 and -3/3 and "Croma Key" as well as "Natural White" are manufactured in large widths of over 500 cm (16,5 feet).

This is a very unusual width for fine fabric looms. Here, the feather-like yarn needs to be shot through the chains by means of shuttles. In order to be able to bridge this distance at all, the shuttle also floats – with the yarn in tow – on a cushion of air towards its intended destination.

- This process produces more than 1.000 cross-points over a single square centimeter. With more than 10.000.000 (10 million) cross-points per square meter.

**Insert, pull tight = secure    Lift = open**

You can get every fold-out of the fabric with the BUNGEE-SNAKE - RUCK - ZUCK - TIGHT!

An end to annoying not making knots or bows. A unique locking system that ensures secure fastening with unlimited adjustment possibilities. Never has set-up been so quick and so precise.

- It is hardly surprising that the first self-adjusting bungee connector between frame and fabric also comes from CALIFORNIA SUNBOUNCE®

Product dimension, weight or look may change without notice



**QUALITY MADE IN GERMANY**



**BUNGEE SNAKE**



**BUNGEE-SNAKE**

**SAND GROOVE CONNECTOR**

The special grooved connector with SAND GROOVE (for all SUNBOUNCE products) prevents the plug-in connection from getting blocked by sand.

- The secret of the super-strong connector – the device that makes the light-weight frame possible in the first place – is the unique DSC-22/25 DOUBLE-SWAGE CONNECTOR: Blocking sand is passed into the sand grooves by a small quarter turn.



**MEASUREMENTS SUN-SCRIM**

- SUN-SCRIM 6' X 6'(183 X 183 cm)
- SUN-SCRIM 8' X 8'(244 X 244 cm)
- SUN-SCRIM 12' X 12'(366 X 366 cm)
- SUN-SCRIM 20' X 20'(610 X 610 cm)



**THE SYSTEM: THE CAGE**



*"YES, I BOUNCE!"*

**NEW! The SUN-CAGE**

**GREG GORMAN'S**

[www.sunbounce.com](http://www.sunbounce.com)

LIGHTING-CAGE by CALIFORNIA SUNBOUNCE

Photo: Esben Melbye



**GREG GORMAN shot "Venus" in THE CAGE**

Photo: Greg Gorman  
Model: Dominique Sharp/  
Model Management LA, Hair and Makeup: Jason Luck

## THE SYSTEM: THE CAGE

### ...THE CAGE

THE CAGE, designed in close cooperation with GREG GORMAN, provides you with a 100% control over your light. Studio or location - midnight or high-noon. Never again you get a problem with uncontrolled spill-light.

Add light, subtract light, get your window-light from any direction. Open the top of your cubic cage and use the soft advantage of a translucent screen minus 2/3rd or close the top to block the light completely from that direction.

Use the bobinette - screen (separate item) in the back to dim your background by 1/2 an f:stop or keep that gate open for most natural look.

You can use walls and top inside-out - so you get unlimited possibilities for your lighting. Sun from the left, sun from the right, sun from the top - no problem anymore.

All these screens are combined in one piece. They are easy to attach to the Aluminum frame-work which sets up in no time. Our SUN-SCRIM SCREENS will be a good choice to add more light-enhancing possibilities to this unique system. For more info please check our web-site frequently as we improve and refine this unique system in the near future more and more.

... GIVES YOU 4 - 6 HOURS ADDITIONAL SHOOTING TIME PER DAY



Photo: Esben Melbye

## THE SYSTEM: THE CAGE

### THE SUN CAGE for the ultimately controlled light environment on location or in the studio



Photo: Esben Melbye

8' x 8' x 8' (245 cm x 245 cm x 245 cm)

The CUBIC MOBILE STUDIO for location-shooting in studio ambience.

For more info please go to the website: [www.sunbounce.com](http://www.sunbounce.com) and check for the Greg Gorman video.

### WALLS AND TOP FOR CAGE

### THE CAGE FRAMEWORK "heavy duty"



### Black Backdrop for THE CAGE

The backdrop for THE CAGE can be attached to back to create a dark black background



**THE SYSTEM: THE MATERIAL**



*"YES, I BOUNCE!"* **SUN-BOUNCE PRO BLACK and SILVER**



**PRO BLACK**



**PRO WHITE**



**PRO SILVER**



## THE SYSTEM: CHARACTERISTICS OF THE LIGHT CHANGE WITH SIZE/

## COLOR AND PATTERN



Size of frame: PRO

Screen color: ZEBRA

Screen color: SILVER

Screen color: WHITE



Size of frame: MINI

Screen color: ZEBRA

Screen color: SILVER

Screen color: WHITE

The photo-documentation is carefully taken with the same exposure and same distance for all photos. The 1.000 watts Arri light is aimed into screen. Minimal light-spill to wall and ceiling might have influenced the appearance.



Size of frame:  
SUN-STRIP

Screen color: ZEBRA

Screen color: SILVER

Screen color: WHITE



Size of frame: PRO

Screen color: -1/3

Screen color: -2/3

Screen color: -3/3

**MORE DETAILS: [WWW.SUBBOUNCE.COM](http://WWW.SUBBOUNCE.COM)**

> SCREENS AND NETS FOR ANY APPLICATION



Silver Screen



Le Louche



-2/3rd



Black Screen



Bobinette

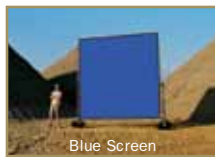

Blue Screen



Green Screen

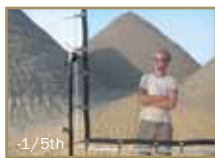

-1/5th

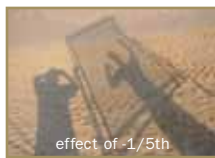

effect of -1/5th

Product dimension,  
weight or look may  
change without notice

> THE FINEST MATERIALS

All of our screens are exclusively made of the finest... reflective and translucent materials available worldwide. Most of them are exclusively made for CALIFORNIA SUNBOUNCE®.

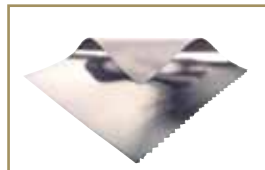

**SILVER/WHITE**

SILVER facing, WHITE backing. The reflection surface reacts neutral without altering the color temperature. Good for people even in red, end-of-day-sun. Also excellent for table top sets.

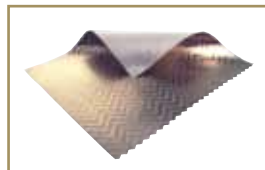

**ZEBRA/WHITE**

ZEBRA (mix of gold and silver in zig-zag design) facing, WHITE backing.

ZEBRA is the workhorse for 90% of all applications and light situations. Reduces the color temperature by about 400 Kelvin. Useful from first sunrise to sunset. The effect is more visible in cold light than in warm light. Skin tone always appears healthy, bright and fresh, and never gold or red.

## THE SYSTEM: THE MATERIAL



### **GOLD/WHITE**

WHITE backing GOLD facing. Gold facing has the reflective surface for very warm light. This GOLD gives you a wonderful warm skin tone in the morning or if the sky is overcast.

In sunny conditions, you will achieve the "butter-cup effect". GOLD reduces the color temperature by about 1,800 Kelvin. SILVER and WHITE react neutral without altering the color temperature. WHITE backing is much softer than GOLD or SILVER.



### **SPARKLING SUN**

Finally - after such a long time and such a great demand - the SPARKLING-SUN is back. This favorite of so many photographers was not available for several years and several reasons. This SPARKLING-SUN adds a completely new light to your bag of tricks.



Product dimension, weight or look may change without notice

## THE SYSTEM: THE MATERIAL



### **BLACK/ ULTRABOUNCE**

BLACK eats light and ULTRABOUNCE creates extremely soft neutral light.



### **BLACK/SILVER RIPSTOP**

BLACK eats light-SILVER RIPSTOP is great for light-boxes:



### **BLACK/SILVER RAINDROPS**

BLACK eats light-RAINDROPS are a little bit sparkling and create "vivid" light



### **BLACK/SILVER ELEPHANT**

BLACK eats light-SILVER ELEPHANT is a little bit sparkling and creates "vivid" light

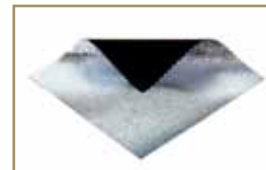

### **BLACK/SILVER GRAIN**

BLACK eats light-SILVER GRAIN is a little bit sparkling and creates "vivid" light



### **BLACK/SILVER INDIA**

BLACK eats light-RAINDROPS are a little bit sparkling and create "vivid" light

See [www.sunbounce.com](http://www.sunbounce.com) and go to "Lighting Effects"



## THE SYSTEM: THE MATERIAL – LE LOUCHE

### LE LOUCHE

CREATE THRILLING PATTERNS OF LIGHT AND SHADE

Le Louche is the best development in light modulation for photo and film to come along in ages. Through the use of two screens it gives the photographer a way of making patterns that break up boring light and give it interest.



SUN-BOUNCE MINI ZEBRA and SUN-SWATTER BIG LE LOUCHE

> **LE LOUCHE – NO MORE BORING FLAT LIGHT!**

A new SUN-SWATTER and SUN-SCRIM (Butterfly) screen with 1001 possibilities.



**LINES**

Cheap clear packing tape creates light shadow. Brown tape creates darker shades



**LEAVES**

Just natural or fake leaves or paper cut-outs produce the ambience of being below a tree or on a terrace in Tuscany.



**CLOUDS**

Thin material or painters foil will give the romantic touch. No sharp focus - always as soft as you like.

> **LE LOUCHE – A CUCOLORIS-TYPE SCREEN**



**SET UP**

Each LE LOUCHE screen comes with one layer of printed leaves on clear PP-foil – noise reduced. Extra leaves can be obtained by the roll - 62"/156cm wide.



**USE**

Available for  
SUN-SWATTER PRO  
SUN-SWATTER BIG  
All SUN-SCRIMS



**RESULT**

Alter the light structure and light character as frequently as you wish.

Product dimension, weight or look may change without notice

Tape

Leaves

Material

FRAMES \ SCREENS	FRAMES														
	MICRO-MINI TRAVELLER	MINI	PRO	BIG	SUN-MOVER	SUN-STRIP MINI	SUN-STRIP PRO	SUN-SWATTER SPOT	SUN-SWATTER MINI	SUN-SWATTER PRO	SUN-SWATTER BIG	SUN-SCRIM 6x6	SUN-SCRIM 8x8	SUN-SCRIM 12x12	SUN-SCRIM 20x20
fabric colors in cm	60 x 90	90 x 125	130 x 190	180 x 245	80 Ø	20 x 125	20 x 190	66 x 66	90 x 125	130 x 190	180 x 245	183 x 183	244 x 244	366 x 366	610 x 610
SILVER / WHITE	●	●	●	●	●	●	—	—	—	—	—	●	●	●	●
ZEBRA / WHITE	●	●	●	●	●	●	—	—	—	—	—	●	●	●	●
GOLD / WHITE	—	●	●	—	—	—	—	—	—	—	—	●	●	●	●
SPARKLING SUN	—	■	■	—	—	—	—	—	—	—	—	—	—	—	—
BLACK/ ULTRABOUNCE	●	●	●	●	—	—	—	—	—	—	—	●	●	●	●
BLACK / SILVER	—	—	●	●	—	—	—	—	—	—	—	●	●	●	●
BLACK / SILVER 3D RAINDROPS	—	—	●	●	—	—	—	—	—	—	—	●	●	●	●
BLACK / SILVER 3D GRAIN	—	—	●	●	—	—	—	—	—	—	—	●	●	●	●
BLACK / SILVER 3D ELEPHANT	—	—	●	●	—	—	—	—	—	—	—	●	●	●	●
BLACK / SILVER 3D INDIA	—	—	●	●	—	—	—	—	—	—	—	●	●	●	●
BOBINETTE	—	—	—	—	—	—	■	■	■	■	■	●	■	■	■
DOUBLER	—	—	—	—	—	—	—	—	■	■	■	●	■	■	■
TRANSLUCENT -1/5th	—	—	—	—	—	—	●	●	●	●	●	●	●	●	■
TRANSLUCENT -1/3rd	—	■	■	●	—	—	■	●	●	●	●	●	●	●	■

FRAMES \ SCREENS	FRAMES														
	MICRO-MINI TRAVELLER	MINI	PRO	BIG	SUN-MOVER	SUN-STRIP MINI	SUN-STRIP PRO	SUN-SWATTER SPOT	SUN-SWATTER MINI	SUN-SWATTER PRO	SUN-SWATTER BIG	SUN-SCRIM 6x6	SUN-SCRIM 8x8	SUN-SCRIM 12x12	SUN-SCRIM 20x20
fabric colors in cm	60 x 90	90 x 125	130 x 190	180 x 245	80 Ø	20 x 125	20 x 190	66 x 66	90 x 125	130 x 190	180 x 245	183 x 183	244 x 244	366 x 366	610 x 610
TRANSLUCENT -2/3rd	—	■	●	●	—	—	—	●	●	●	●	●	●	●	■
TRANSLUCENT -3/3rd	—	—	—	—	—	—	—	■	●	●	●	●	●	●	■
TRANSLUCENT LE LOUCHE	—	—	—	—	—	—	—	●	●	●	●	●	●	●	■
NO MOIRÉ WHITE	—	—	—	—	—	—	—	●	●	●	●	●	●	●	■
TUSCANY	—	—	—	—	—	—	—	■	■	■	■	■	■	■	■
MOLTON heavy 160g	—	—	—	—	—	—	—	—	—	—	—	■	■	■	■
MOLTON heavy 300g	—	—	—	—	—	—	—	—	—	—	—	●	●	●	●
POLYESTER BLACK	—	—	—	—	—	—	—	—	—	—	—	●	●	●	■
REFLEX NATURAL WHITE	—	—	—	—	—	—	—	—	—	—	—	●	●	●	■
BLUE BOX	—	—	—	—	—	—	—	—	—	—	—	■	■	■	■
GREEN BOX	—	—	—	—	—	—	—	—	—	—	—	■	■	■	■
WIND-KILLER	—	■	■	■	—	—	—	—	—	—	—	●	●	●	●

● available as Kit ■ parts separate ● on request — not available for this frame

## NEW: THE SUNBOUNCE PHOTO & LIGHTING WORKSHOPS

### MIKE LARSON'S PHOTOGRAPHY BUSINESS and LIGHTING LECTURE on FOUR DVDs

#### FROM PASSION TO SUSTAINABLE PHOTO BUSINESS IN FIVE HOURS!



WOLFGANG-PETER GELLER, two-time winner of the WORLD PRESS PHOTO AWARD

#### THE KEY ELEMENTS OF SUCCESSFUL PHOTOGRAPHY

„These four MIKE LARSON'S PHOTOGRAPHY BUSINESS and LIGHTING LECTURE DVDs might turn out to be the cheapest yet most valuable investment in your photographic career. When used right, they can boost your business to unimagined dimensions!“

- ✓ MIKE LARSON REVEALS THE SECRETS OF HIS SUCCESS IN PHOTOGRAPHY AS NEVER DONE BEFORE.
- ✓ MIKE SHARES EVERYTHING AND HOLDS NOTHING BACK.
- ✓ HUNDREDS OF SAMPLE PHOTOS, TABLES AND HIGHLY PROFESSIONAL LIVE SHOOTING VIDEOS MAKE IT EASY TO FOLLOW AND UNDERSTAND MIKE'S IDEAS AND BUSINESS MODELS.



MIKE LARSON, wedding photographer

**WWW.SUNBOUNCE.COM**  
PHOTO & LIGHTING WORKSHOPS

## NEW: THE SUNBOUNCE PHOTO & LIGHTING WORKSHOPS

DVD 1



#### Rise Above The Crowd! Enhance Your Leadership Skills & Reputation As A Photographer. Including 6 LIVE SHOOTS

From Startup To Success – The Most Influential Image – Studio Lounge – Leadership – Worst Light Of The Day – Integrity, Respect, Timing – Team Approach – Client Relation – Brand Yourself – Freedom For Yourself – Fun With Customers

DVD 2



#### Be A Successful Photographer! Develop Your Own Style Of Shooting To Success. Including 4 LIVE SHOOTS

Innovation - Directing – Camera Toss – Mike's Bag Of Gear – Twitter, Facebook, Blogging – Old New Media - Relationship & Influence – Avoid Postproduction – Efficient Selling – Pricing – Rim Light – Cooperation

DVD 3



#### Shoot Right The First Time – Make That Your Goal! Use Mike Larson's Magic Tricks To Land The Big Jobs. Including 6 LIVE SHOOTS

Time Savers – Practice Sessions – Lighting Set-Ups – Shooting Style – Manipulate Light – Style And Vision – Posing – Camera Settings & Techniques – Create Masterpieces – Swatt The Light – Getting Clients – Popping Images – Assistants – Scenarios – Lead Your Clients.

DVD 4



#### Become Successful As Quickly As Mike Larson – Mike Shares His Greatest Secrets With You. Including 9 LIVE SHOOTS

Customer Evangelists – Mike's Studio – Client Treatment – Growth Principals – Referral Based Business – Learn Fast – Move The Sun – Goals – Time & Profit – On Or In Your Business – Outsourcing – Exposure – Shooting Techniques – Business Charts

## THE PRODUCTS



**SUN-BOUNCE MICRO-MINI**  
2' x 3' (60 x 90 cm)

**SUN-BOUNCE MINI**  
3' x 4' (90 x 125 cm)

**SUN-BOUNCE PRO**  
4' x 6' (130 x 190 cm)

**SUN-BOUNCE BIG**  
6' x 8' (180 x 245 cm)



**SUN-STRIP MINI**  
36" x 7,9" (125 x 20 cm)

**SUN-STRIP PRO**  
72" x 7,9" (180 x 20 cm)



**SUN-SWATTER MINI**  
3' x 4' (90 x 125 cm)

**SUN-SWATTER PRO**  
4' x 6' (130 x 180 cm)

**SUN-SWATTER BIG**  
6' x 8' (180 x 245 cm)

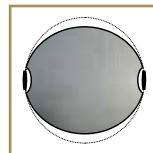

**SUN-MOVER**  
silver/ white (seamless)

**SUN-MOVER**  
zebra/ white (seamless)

Product dimension, weight or look may change without notice

## THE PRODUCTS



**SUN-SWATTER SPOT**



**SUN-SCRIM 6'x 6'**  
183 x 183 cm

**SUN-SCRIM 8'x 8'**  
244 x 244 cm

**SUN-SCRIM 12'x 12'**  
366 x 366 cm

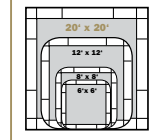

**SUN-SCRIM 20'x 20'**  
610 x 610 cm

Product dimension, weight or look may change without notice

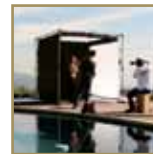

**THE CAGE**



**BLACK BACKDROP**  
for THE CAGE



**SUN-BOUNCE WIND-KILLER**  
STATIC PRO

**SUN-BOUNCE WIND-KILLER**  
STATIC BIG

**SUN-BOUNCE WIND-KILLER**  
MOBILE MINI



**SUN-BOUNCE WIND-KILLER**  
MOBILE PRO

**SUN-BOUNCE WIND-KILLER**  
MOBILE BIG



## THE PRODUCTS



### BELT-CLIP

When both hands are busy, pop your MICRO-MINI reflector to your HANDS-FREE BELT CLIP. A new tool from CALIFORNIA SUNBOUNCE to make you more independent from assistants.



### BOOM-STICK "ONE RISER"

(fully extended) 219 cm/9'

### BOOM-STICK "TWO RISER"

(fully extended) 319 cm/9'



### SWATTY PRO

### SWATTY BIG

**NEW!**

„The perfect connection between your SUN-SWATTER crossbar and your BOOM-STICK. Now the SUN-SWATTER can easily flip over and flip back again when the wind gets out of control - without damaging the crossbar.“



### BOOM-SUPPORT "FOR BELT"

Product dimension, weight or look may change without notice

## THE PRODUCTS



### GRIP-HEAD ENTERPRISE

**NEW!**



### TUNING-CLIP PRO

### TUNING-CLIP BIG

Product dimension, weight or look may change without notice



### TUBE-CONNECTOR PRO

### TUBE-CONNECTOR BIG

**NEW!**



### MINI CENTER-BAR

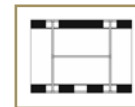

**NEW!**



### BUNGEE-SNAKE

## THE PRODUCTS



**ROLLER-BAG Black**  
made from strong Truck Tarpaulin

**MEASUREMENTS**

Lenght main bay: 53"/135 cm  
Depth: 11"/ 27 cm  
Hight: 7"/18 cm  
Outside pouches: 15"x7"x2"/37x18x6 cm  
Weight: 6 pound/2.8 kg



**NEW!**



**CARRYING-BAG 135 Black**  
**CARRYING-BAG 150 Black**

**MEASUREMENTS 135**

Flat: 53"x11"x1"/135x28x3 cm  
Weight: 1 pound/460 gr

**MEASUREMENTS 150**

Flat: 59"x11"x1"/150x28x3 cm  
Weight: 1,3 pound/600 gr

Product dimension, weight or look may change without notice



**SCREEN-SAVER**  
for two screens PRO.  
Including ID-Windows.

**MEASUREMENTS**

Flat: 15"x11"x1"/38x28x3 cm  
Weight: 0,2 pound/92 gr



**SCREEN-SAVER BAG Medium**  
for SUN-SCRIM screens:  
Including ID-Windows also  
at bottom.

**MEASUREMENTS**

Flat: 20"x14"/52x36 cm  
Weight: 0,5 pound/262 gr



**SCREEN-SAVER BAG Large**  
for SUN-SCRIM screens.  
Including ID-Windows also  
at bottom.

**MEASUREMENTS**

Flat: 24"x19"/ 62x48 cm  
Weight: 0,75 pound/350 gr

## THE PRODUCTS

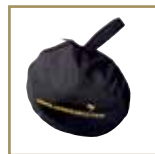

**DRESS-TUBE Black only**  
Supports fast change of outfit  
on location. Saves a lot of time.

Dimesion packed: 28x3 cm/ 11"x1"  
Dimesion in use: 78x122 cm/31"x48"

Product dimension, weight or look may change without notice



**SAND-BAG for 15 kg**  
Bag without weight



**ADAPTER FOR SAND-BAG**

## THE PRODUCTS

### THE LOCATION-TRUCK



### FOLD-IT TRUCK

- > Folds easily for convenient storage
- > Weighs only 33 lbs, but can haul up to 330 lbs.
- > Completely rust and corrosion resistant



### MEASUREMENTS FOLD-IT TRUCK

- > Hauling capacity: 5.75 cubic feet, 330 pounds
- > Inside dimensions: 38" Long x 22.75" Wide x 11.5" Deep
- > Overall dimensions: 55" Long x 30.25" Wide x 23" Deep
- > Folded dimensions: 41" Long x 9.5" Wide x 22" Deep
- > Sturdy all-aluminum construction
- > Limited 2-year warranty

Product dimension, weight or look may change without notice

## THE PERFECT TEAM: SUN-SWATTER & SUN-BOUNCE



[WWW.SUNBOUNCE.COM](http://WWW.SUNBOUNCE.COM)

[WWW.SUNBOUNCE-USA.COM](http://WWW.SUNBOUNCE-USA.COM)



SUNBOUNCE GmbH • Siems Twieten 4 • 21376 Garlstorf – Germany • Phone: +49 (4172) 987 87 87

Fax: +49 (4172) 987 87 67 • e-mail: [info@sunbounce.com](mailto:info@sunbounce.com) • [www.sunbounce.com](http://www.sunbounce.com)



# SUN SNIPER

www.SUN-SNIPER.com

The revolutionary SNIPER STRAP system by SUN-SNIPER.

Perfect for the single camera shooter as well as for the war correspondent with three cameras ready to shoot in a split-second.



2

## THE NEW GENERATION OF HIGH-TECH SNIPER CAMERA STRAPS

The SUN-SNIPER-STRAP is the next generation of fast, smooth and ultra-comfortable camera straps for professional photographers. Coming with an integrated SHOCK-ABSORBER, CUTTER-CRASHER and a genuine stainless steel bearing, it is the sensation for D-SLR-PROS. The SNIPER-STRAP is worn diagonally and evenly distributes the weight through the ergonomic shoulder pad and relieves the back and shoulders – even when using heavy weight cameras. The camera hangs at the waist and can be hoisted quickly, safely and always ready to shoot.

### COMFORTABLE/ EASY ON YOUR BACK



...thanks to the integrated shock absorber and because weight is distributed diagonally.

SUN SNIPER  
www.SUN-SNIPER.com

3

## THE SUN-SNIPER-STRAP FAMILY

is the new generation of safe, fast, smooth, and ultra comfortable camera supports for professional photographers. Now with friction eliminating genuine STAINLESS STEEL BEARING for better spinning and less swinging.



WOLFGANG-PETER GELLER, owner of SUNBOUNCE GmbH and SUN-SNIPER GmbH, two time winner of the WORLD PRESS PHOTO Award and one of the winning photos

Geller was inspired by the US Cavalry Carbine 1885 Sling – produced at Rock Island Arsenal – in the design of his ultimate SNIPER-STRAP SYSTEM for fastest modern action shooting. Geller also added some nice features like a thief-proof steel wire, as well as a shock absorber to compensate for the growing weight of modern SLR cameras.

The latest development is the friction eliminating genuine STAINLESS STEEL BEARING for better spinning and less swinging. This new camera strap connector development also shortens the physical distance between camera and strap and reduces unwanted swinging drastically.

You will enjoy the new feeling of safe, fast, smooth action shooting with the SNIPER-STRAP SYSTEM. When you buy a SNIPER-STRAP please always check for:

- SHOCK-ABSORBER
- STEEL WIRE protection
- STAINLESS STEEL BEARING (Made in Europe)

Genuine, highest quality SNIPER-STRAPS are made by SUN-SNIPER GmbH, Germany. The SNIPER-STRAPS are designed with the experience of more than 35 years of daily extensive photographic challenges.



## THE MOST INNOVATIVE HIGH-TECH

## CAMERA CARRYING SYSTEM

### THE "PRO" STEEL & BEAR

### THE "COMPACT" STEEL & BEAR

### THE "ONE" – THE ORIGINAL

### THE PRO STEEL & BEAR "LEATHER"

### THE "DPH" DOUBLE PLUS HARNESS STEEL & BEAR

### THE "TPH" TRIPLE PRESS HARNESS STEEL & BEAR

### THE "AC" ACTIVITY CLIP

### THE "BPS" BACK-PACK-STRAP STEEL & BEAR

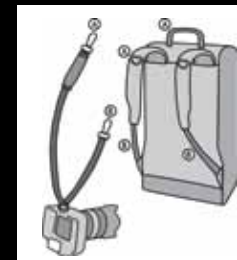

The high-end solution  
for the professional  
photographer

Compact, super light and handy –  
for all compact cameras

Comfortable – the ORIGINAL for  
all D-SLR cameras

Classy, exquisite and stylish.  
Timeless elegance for the  
discerning photographer

For press, wedding and  
sports photographers,  
up to 3 cameras

For the „Pro on the Go“ who  
needs to have his equipment at  
his side at all times

The ACTIVITY-CLIP keeps  
the camera locked in perfect  
position when needed

The special SNIPER-CAMERA  
STRAP for your existing  
backpack

DETAILS PAGE 10-11

DETAILS PAGE 12-13

DETAILS PAGE 14

DETAILS PAGE 15

DETAILS PAGE 20-21

DETAILS PAGE 22-25

DETAILS PAGE 26

DETAILS PAGE 27

# 7

## GOOD REASONS TO

## CHOOSE THE SNIPER-STRAP

### 1. FASTEST ACTION...

### 2. HIGH-TECH BEARING...

### 3. EVEN SAFER...

### 4. LESS SWINGING – BETTER SPINNING...

### 5. INSURANCE PROTECTED...\*

### 6. COMFORTABLE AND EASY ON YOUR BACK...

### 7. FINEST MATERIALS...



#### SNIPER-STRAP

... because the camera is hanging upside down, in the perfect position



#### SAFE CAMERA

... for the ultimate in safe camera connection"



#### STEEL WIRE

... by innovatively integrated strong safety steel wire



#### STEEL BEARING

... due to the frictionless genuine STAINLESS STEEL BEARING



#### KNIFE PROOF

you are insured for up to \$500 USD or 400 EUR\*



#### SHOCK-ABSORBER

... thanks to the integrated shock-absorber and ergonomic padding with anti-slip material



#### „BALLISTIC NYLON“

...the most durable "Ballistic Nylon", the strongest Neoprene, and high quality leathers (when used)

## THE "PRO" STEEL & BEAR –

## THE CHOICE FOR THE PROFESSIONAL PHOTOGRAPHER

### THE "PRO" STEEL & BEAR

In addition to the STEEL safety feature the "PRO" STEEL & BEAR adds a friction eliminating genuine **STAINLESS STEEL BEARING** for better spinning and less swinging. This new camera strap connector development also shortens the physical distance between camera and strap and reduces unwanted swinging drastically.

- ✓ NEW! Friction eliminating genuine **STAINLESS STEEL BEARING** for better spinning
- ✓ less unwanted swinging
- ✓ **INSURANCE PROTECTED\***
- ✓ **SHOCK-ABSORBER**
- ✓ **CUTTER-CRASHER**

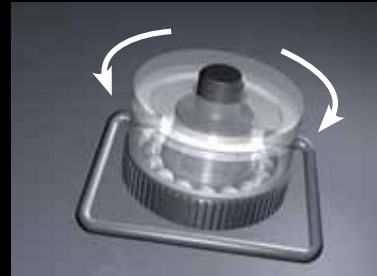



## THE "COMPACT" STEEL & BEAR –

## THE CHOICE FOR EVERY COMPACT KAMERA

### THE "COMPACT" STEEL & BEAR

The "COMPACT" STEEL & BEAR is the little brother in the SUN-SNIPER family. It's designed for all compact cameras and comes with the **SHOCK-ABSORBER**, **THIEF PROTECTION** as well as its own cute little **STAINLESS STEEL BEARING**. It has exactly the same quality features as the "PRO" – just everything a little more compact.

- ✓ NEW! Friction eliminating genuine **STAINLESS STEEL BEARING** for better spinning
- ✓ less unwanted swinging
- ✓ **INSURANCE PROTECTED\***
- ✓ **SHOCK-ABSORBER**
- ✓ **CUTTER-CRASHER**



## ▶ THE "ONE" – THE ORIGINAL



### THE "ONE" – THE ORIGINAL

The "ONE" is the ORIGINAL for all D-SLR cameras. The **SHOCK-ABSORBER** is integrated into the strap and makes carrying the camera even more comfortable.

The camera hangs at the waist and can be hoisted **QUICKLY**, safely and ready to shoot. It allows the photographer to intuitively find the handle and the shutter button without losing sight of the subject. He can effortlessly move the camera to his face and capture images that would previously have been lost. With the innovative **RAIL-WAY strap**, the carabiner glides along the strap to your eye as if it were on rails - without great frictional resistance.



## ▶ THE PRO STEEL & BEAR "LEATHER"



### THE PRO STEEL & BEAR "LEATHER"

**FINEST COWHIDE, CAREFULLY MANUFACTURED**

Classy, exquisite and stylish. This **PRO STEEL & BEAR "LEATHER"** is made of the finest, super soft leather, having all the unique features of the **SNIPER-STRAP "PRO"**. Timeless elegance for the discerning photographer.



▶ **WHAT THE PHOTO EXPERT SAYS:**



**GERD LUDWIG**

**„THE SUN-SNIPER STRAPS  
ARE REVOLUTIONARY AND  
BRILLIANT“**

**ONE OF THE WORLDS BEST  
DOCUMENTARY PHOTOGRAPHERS**

*(works for National Geographic Magazine and other leading publications)*

Gerd Ludwig, Los Angeles/USA  
photo by Douglas Kirkland

▶ **WHAT THE ORTHOPEDIC EXPERT SAYS:**

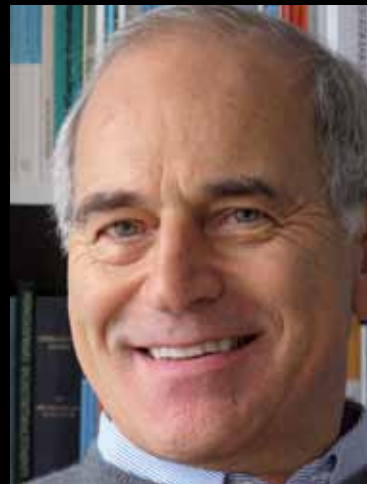

**DR. MED. STEPHAN REDECKER**

Dear Mr. Geller,  
Thank you for your demonstration of the SUN-SNIPER camera strap. The SNIPER-STRAP fits very ergonomically to the body. The diagonal path of the strap enables the camera to be carried on the photographer's side, unlike other straps that suspend the camera in front of the wearer's chest or abdomen. This is much better for the back, because strain to the kyphosis is eliminated. **THE – ELASTIC – SHOCK ABSORBER SECTION OF THE STRAP ACTS AS AN EXCELLENT BUFFER.** For all of these reasons the SUN-SNIPER is highly recommended from an orthopedic and sports medicine point of view for carrying heavy cameras.



**DR. MED. STEPHAN REDECKER,**  
Orthopedic and sports medicine specialist,  
Hamburg/ Germany

## GENUINE STAINLESS STEEL BEARING –

## THE MOST ADVANCED COUPLER BEARING

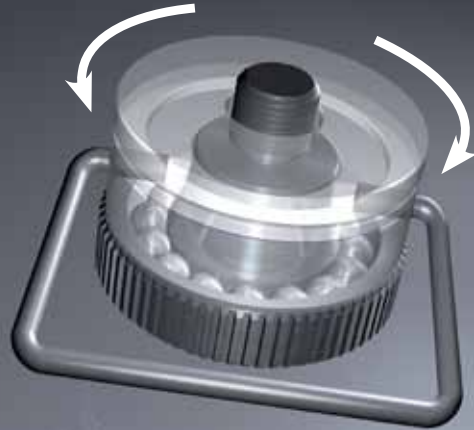

**\*NEW! Now with GENUINE STAINLESS STEEL BEARING for better spinning and less swinging.**

The SUN-SNIPER SYSTEM with SHOCK-ABSORBER, CUTTER-CRASHER and GENUINE BEARING is the sensation for D-SLR-PROS: It is the fastest and most comfortable SNIPER-STRAP in the world. A MUST-HAVE for all D-SLR photographers, whether you are PRO or SEMI-PRO it is as ingenious as it is simple.



## THE "DPH" – DOUBLE PLUS HARNESS – STEEL & BEAR

### THE "DPH" – DOUBLE PLUS HARNESS – STEEL & BEAR

The comfortably designed SUN-SNIPER DOUBLE-PLUS-HARNESS for news, wedding and sports photographers is made for **TWO MAJOR CAMERAS** plus **ONE SMALLER CAMERA** or a pair of binoculars. Have all your gear right at your body.

- ✓ NEW! Friction eliminating genuine **STAINLESS STEEL BEARING** for better spinning
- ✓ less unwanted swinging
- ✓ **INSURANCE PROTECTED\***
- ✓ **SHOCK-ABSORBER**
- ✓ **CUTTER-CRASHER**



SHOCK-ABSORBER

RAIL-WAY STRAP

CUTTER-CRASHER

HIGH-TECH CONNECTOR



## THE "TPH" – TRIPLE PRESS HARNESS – STEEL & BEAR

### THE "TPH" – TRIPLE PRESS HARNESS – STEEL & BEAR

#### THREE PROFESSIONAL CAMERAS.

Easy to carry and **SNIPER-FAST** in action whether you are a war correspondent or shoot in football or soccer stadiums, you will love always having the perfect camera ready to go and still have everything you might need right at your side. You do **NOT** have to leave unattended gear behind.

- ✓ NEW! Friction eliminating genuine **STAINLESS STEEL BEARING** for better spinning
- ✓ less unwanted swinging
- ✓ **INSURANCE PROTECTED\***
- ✓ **SHOCK-ABSORBER**
- ✓ **CUTTER-CRASHER**

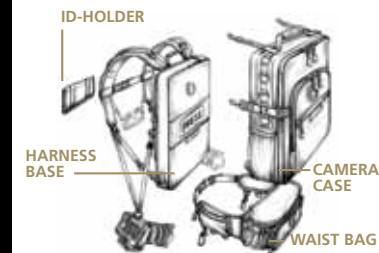

## THE "TPH" – TRIPLE PRESS HARNESS – STEEL & BEAR

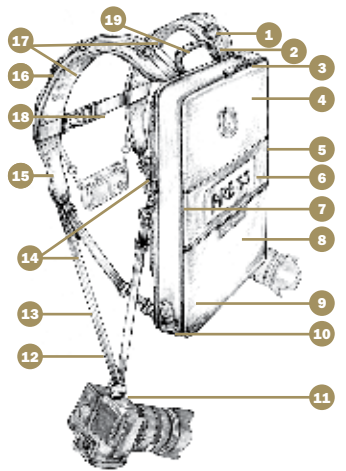

1. all D-RINGS are made from steel
2. HARNESS STRAPS are also protected with steel wire
3. zipper garage
4. case for most 17" Laptops with integrated unique SHOCK-ABSORBER just for the laptop as well as a solid and stiff plate to protect against torsion and pressure - impact on the Lap-Top
5. extra case for documents
6. ID-Holder
7. extra strong 10 mm zipper
8. entire shell made from sturdiest BALLISTIC NYLON
9. thick industrial thread material
10. connector for WAIST-BAG or other accessories
11. STAINLESS STEEL BEARING for smooth spinning and less swinging – Made in Europe
12. RAIL-WAY belt for smoother gliding
13. cutter proof SNIPER STRAPS, insured\*
14. two adjustable SNIPER-STRAPS with integrated SHOCK ABSORBER
15. harness straps thick soft padding for comfort on long trips without neck or back pain
16. many extra D-rings as back-up docks for accessories
17. inner backside sweat absorbing comfort padding
18. front strap for better positioning
19. extra carrying handle

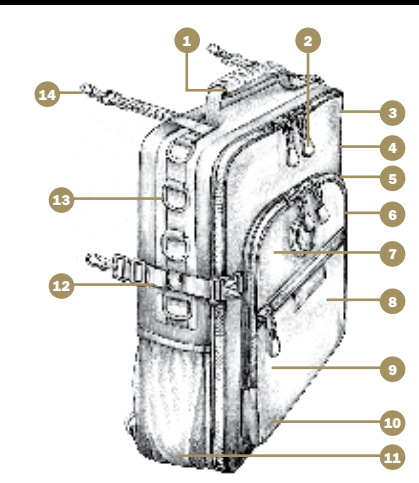

1. carrying handle
2. extra strong zipper - 10mm
3. two straps for tripod
4. inside orange lining for clear viewing
5. inside sturdy padding
6. inside rich number of self adjustable seperators
7. utility case
8. entire shell made from sturdiest BALLISTIC NYLON (even the backside and bottom)
9. document pouch
10. thick industrial thread material
11. elastic net for water bottle
12. two adjustable safety straps
13. lots of extra D-rings for this and that
14. connectors to Harness

### THE "TPH" BASE

Height: 420 mm  
Width: 300 mm  
Depth: 80 mm  
Weight: 1.700 grams

### THE "TPH" CAMERA CASE

Height: 450 mm  
Width: 380 mm  
Depth: 150 mm  
Weight: 1.850 grams

### THE "TPH" WAIST BAG

Height: 150 mm  
Width: 270 mm  
Depth: 150 mm  
Weight: 700 grams

### THE "TPH" ID-HOLDER:

Height: 100 mm  
Width: 200 mm  
Depth: 15 mm  
Weight: 100 grams

## ► THE “AC“ ACTIVITY CLIP

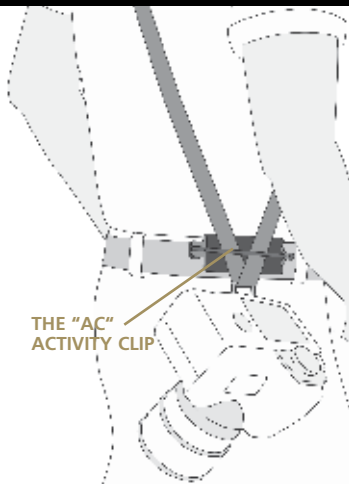

### THE “AC“ ACTIVITY CLIP

#### LOCKED POSITION WHEN RUNNING, BIKING OR CLIMBING

The ACTIVITY-CLIP keeps the camera locked in perfect position when needed – still ready to shoot. The camera can be quickly locked at a perfect position and released in the same way. The ACTIVITY-CLIP is simply attached to the belt. Whether you are walking, running or climbing – with the ACTIVITY-CLIP - the camera will reliably stay in perfect position. The ACTIVITY-CLIP guarantees secure locking of the camera. The ACTIVITY-CLIP can be used with all single straps as well as with the DPH and TPH. Use on either side is convenient.

## ► THE “BPS“ – BACK-PACK-STRAP STEEL & BEAR

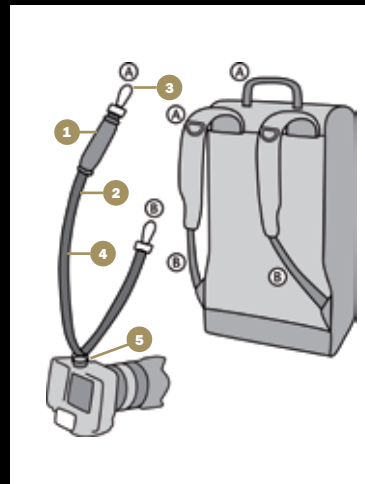

### THE “BPS“ – BACK-PACK-STRAP

WITH STEEL & BEAR. FOR ALMOST ALL BRAND BACKPACKS WITH TOP POSITION-D-RINGS OR CENTER HANDLE

When you are outside, carrying your own backpack for your notebook, camera or gear, you don't want to carry an additional camera strap around your neck or gear. Now the genuine SUN-SNIPER BACKPACK STRAP with SHOCK-ABSORBER, BEARING CAMERA CONNECTOR and RAIL-WAY can be attached to almost any backpack. The “BPS“ BACK-PACK-STRAP STEEL & BEAR is a special camera strap for backpackers, nature photographers, climbers and everyone carrying a backpack. Via the backpack's shoulder pad the weight of the camera is evenly distributed to the shoulders. Additionally, the SHOCK-ABSORBER cushions heavy thrusts. The camera is hanging in perfect position, always ready to shoot.

1. SHOCK-ABSORBER
2. RAIL-WAY STRAP
3. CARABINES
4. CUTTER CRASHER/INSURED\*
5. HIGH-TECH BEARING CONNECTOR



## THE SUN-SNIPER STRAP FAMILY



**The "COMPACT" STEEL & BEAR**  
small and smooth for compact cameras  
> **product code: SSN-COM**



**The "ONE"**  
Rigid. The STANDARD for all D-SLR cameras  
> **product code: SSN-1BB** (black/black)  
> **product code: SSN-1BG** (black/gold)



**The "PRO" STEEL & BEAR**  
The HIGH-END-SOLUTION for the PRO  
> **product code: SSN-PRO**

## THE SUN-SNIPER STRAP FAMILY



**The "DPH" – DOUBLE PLUS HARNESS – STEEL & BEAR**  
for the NEWS-, WEDDING- and SPORTS- PRO for 3 cameras  
> **product code: SSN-DPH**



**The "TPH" – TRIPLE PRESS HARNESS – STEEL & BEAR**  
for the „PRO on the GO“ who needs everything on his body  
(3 cameras, laptop, charger)  
> **product code: SSN-TPHB**



**The PRO STEEL & BEAR "LEATHER"**  
For the discerning photographer with timeless elegance  
> **product code: SSN-LPR**

## THE SNIPER STRAP ACCESSORIES



**The "TPH" – TRIPLE PRESS HARNESS – CAMERA CASE**

> product code: **SSN-TPHCC**



**The "TPH" – TRIPLE PRESS HARNESS – ID-HOLDER**

> product code: **SSN-TPHID**



**The "TPH" – TRIPLE PRESS HARNESS – BASE**

> product code: **SSN-TPHB**



**The "TPH" – TRIPLE PRESS HARNESS – WAIST BAG**

> product code: **SSN-TPHWB**

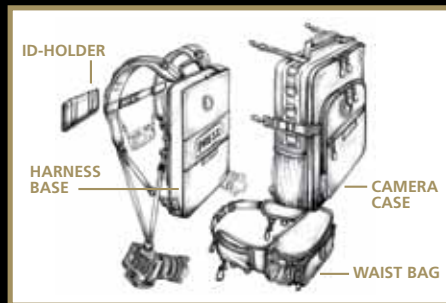

## THE SNIPER STRAP ACCESSORIES



**SNIPER-STRAP BEAR Camera Screw**

> product code: **22 mm SSN-BCS**  
> product code: **16 mm SSN-BCSS**



**THE "AC" ACTIVITY CLIP**

> product code: **SSN-ACL**



**THE "BPS" BACK-PACK-STRAP**

Make your own SUN-SNIPER Back-Pack-Strap

> product code: **SSN-BPS**



**SNIPER-STRAP PAD CAMOUFLAGE**

for "ONE", "STEEL", "PRO" – STEEL & BEAR

> product code: **SSN-PCA**

---



**SUN SNIPER**  
*www.SUN-SNIPER.com*

---



**THE NEW GENERATION OF CAMERA SUPPORT SYSTEMS**

**SUN-SNIPER GmbH** • Siems Twieten 4 • 21376 Garlstorf – Germany • Phone: +49 (4172) 987 87 88

Fax: +49 (4172) 987 87 68 • e-mail: [info@sun-sniper.com](mailto:info@sun-sniper.com) • [www.sun-sniper.com](http://www.sun-sniper.com)