



Multi-Format Broadcast and Professional Monitors
2016 Product Line-up Ver 1.1

Total Solution for Broadcast Display



TVLogic Product Lineup 2016



	VFM	RKM	LVM/SRM	SWM	LHM	XVM	LEM	LUM
3"~		535A 443A						
5"~	056WP 058W	356A						
7"~		270A	070C 075A SRM-074W-N					
9"~		290A	095W-N					
17"~			170A 171A <i>coming soon</i> 182W-A	171A		177A		171G
20"~			212W					
23"~			232W-A 245W 246W	240A		245W-N	250A	240G
30"~			327W	320A		325W		310A
40"~				420A 460A 550A	420A 460A 550A			

Viewfinder
VFM-056WP 08
VFM-058W 09

Rack Mountable
RKM-535A *New* 10
RKM-443A/356A 11
RKM-270A/290A 12

Multi Format Monitor
LVM-070C *New* 13
LVM-075A *New* 14
SRM-074W-N 15
LVM-095W-N 16
LVM-170A 17
LVM-171A *Coming soon* 18
LVM-182W-A 19
LVM-212W 20
LVM-232W-A 21
LVM-245W 22
LVM-246W 23
LVM-327W 24

Studio Wall Monitor
SWM-171A *New* 25
SWM-240A 26
SWM-320A 27
SWM-420A 28
SWM-460A 29
SWM-550A 30

Multi Viewer Monitor
LHM-420A / 460A / 550A 31

Precision Monitor
XVM-177A *New* 32
XVM-245W-N 33
XVM-325W 34

OLED Monitor
LEM-250A 35

12G / 4K Monitor
LUM-171G *New* 36
LUM-240G *New* 37
LUM-310A 38

Optional Accessories 39

About TVLogic Monitors

Accurate Color, Precise Calibration, and Field Upgradability

Accurate Color Reproduction

TVLogic monitors support color gamuts that conform to the ITU standard and match EBU/Rec. 709 specifications for HD broadcast video, allowing for accurate and standardized color reproduction.

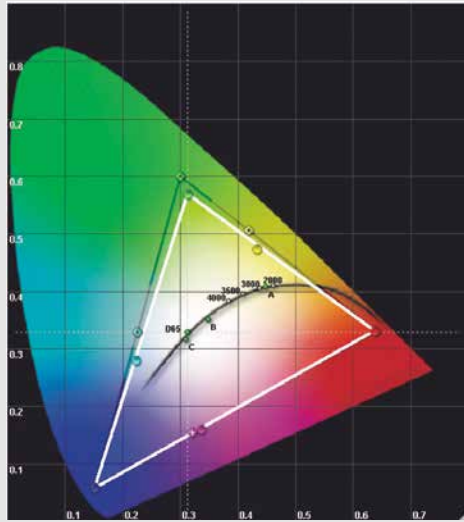

Field Upgradability

All TVLogic monitors are field upgradable using an optional handheld upgrade tool that quickly and easily loads firmware updates into individual monitors.

TVLogic offers all standard feature upgrades and firmware updates free for a period of two years to users who update a supported TVLogic monitor via our handheld upgrade tool.



Observer system

'Observer' is a free wall monitor management software via network. It provides you with comprehensive control over the multiple monitors via Ethernet or RS-422. Turning on and off the power, controlling the OSD menu or short cut keys can be managed on the user's PC. Observer also provides firmware upgrade functions, which are only available via an Ethernet connection.



Color Calibration

All TVLogic monitors are calibrated prior to shipment for optimal luminance, gamma and color temperature measurements. With use, however, backlights age differently, as do OLED phosphors.

So, we also offer a free TVLogic Color Calibration Utility that automatically realigns our monitors for accurate color reproduction. Four different measurement probes are supported that cover various requirements of sensitivity, speed and budget.

TVLogic recommends the Klein K-10A probe as it offers both fast and highly accurate calibration as well as broad compatibility with the entire TVLogic line. Additional supported probes include the X-Rite i1Display Pro by TVLogic OEM (included with TVLogic Color Calibration Utility Software), as well as the more advanced Konica Minolta CA-210 Color Analyzer and DK Technologies PM5639.

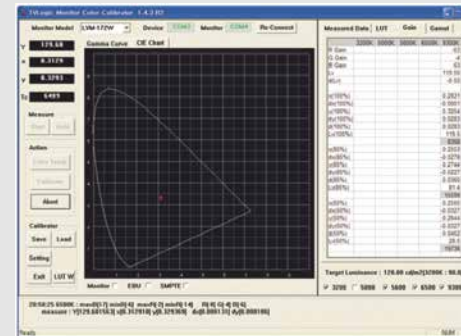

Preferred Features

Most TVLogic monitors are bundled with standard desktop stands and offer many features such as 608/708 closed captioning support, 3D LUT import and export, Active Format Description support, built-in Waveform and Vectorscope, 3G input, rack mount options and more that make them the most versatile broadcast and professional monitors in the industry.

About TVLogic Monitors

Industry-Leading Broadcast Features and Superior Video Engineering

TVLogic® Always ON-AIR



Broadcast Features

- Multi-Format Support (480i, 480p, 576i, 576p, 720p, 1080i, 1080p, 1080PsF, 2K, 4K)
- Assignable Remote Control
- H/V Delay / User Aspect
- Blue Only / Mono
- Wide Variety of Markers & Safety Areas including User Defined Markers
- AutoSensing AutoSwitching HD/SD-SDI Inputs
- Multi-Format Analog / Digital Signal Support (CVBS / S-Video / Component Video / RGB / DVI or VGA / HDMI)
- HDMI input (HDCP decryption)
- 2 x Reclocked Active Thru (SDI)
- 3G / Dual-Link compatibility on 5.5", 5.6", 7", 9", 17", 18", 21", 23", 24", 32", 42", 46", and 55" units (except LVM-XX2Ws)
- Built in Audio Disembedder and Internal Speakers
- Selectable Color Temperature (3200K, 5000K, 5600K, 6500K, 9300K and user-defined modes)
- Source ID function / UMD (ANC, Manual, Dynamic and User)
- Timecode display (VITC & LTC)
- Closed Caption decoding (CEA-608 / 708)
- Brightness, Contrast, Chroma, Hue and Backlight adjustability
- Waveform / Vectorscope
- Firmware update using TVLogic Update Tool

Flexibility

True Multi-Format Support

SD and HD digital as well as analog TV standards (NTSC, PAL, SECAM) are fully supported. Additionally, VGA, DVI, Component, CVBS, S-VIDEO, HDMI, 3G-SDI support is standard on LVM-XX3Ws, LEM, LUM, TDM and XVM series monitors.

Slim & Smart Design

Slim, single-piece integrated design and easy-to-use rack mount kits for 7" - 24" monitors allow for flexible installation with any application from mobile production to master control room and everything in between.

Superior Picture Quality

Full Native HD Resolution

The 5.5", 7", 9", 17", 21", 23", 24", 32", 42", 46", 47" and 55" models support native Full HD resolution of 1920 x 1080 pixels.

Models 18.5" and below offer full native resolution support of 720p. All monitors are capable of full screen native, full screen scaled or 1:1 pixel mapped display at each screen's maximum resolution.

And all models can be automatically calibrated with our optional Color Calibration Utility.

Industry-Leading Video Processing

TVLogic monitors integrate our proprietary Advanced Digital Signal Processing Algorithms with an unparalleled video processing, scaling and deinterlacing architecture to provide superior video quality and accurate picture reproduction for every monitor in TVLogic's extensive product line.

Accurate Colorimetry

TVLogic's advanced automatic alignment technology ensures matching displays that are calibrated to precise Rec. 709 (=ITU-R BT.709) specifications.



↑ VFM Series

The VFM-056WP and VFM-058W are ideal for small camera/HDSLR production. A compact and light-weight magnesium-alloy case houses a 5.6" native 1280x800 resolution and 5.5" Full HD 1920x1080 resolution LED backlight LCD display with a full complement of preferred features, including DSLR Scale, Focus Assist, Various Scan Modes, Markers, Audio Level Meter with speaker, Time Code Display, HDMI-SDI conversion output, Waveform/Vectorscope, Luma(Y') Zone Check and Range Error.

The VFM-056WP and the VFM-058W offer outstanding picture quality and include mounting holes on top, bottom, right and left for convenient mounting on or near the camera. TVLogic also provides various optional accessories including Sun-Hood, Acrylic Protector Screen and Battery Brackets to meet the needs of professional HDSLR and Compact Digital Cinema Camera operators.



← LHM Series

The LHM Series offers cost-effective performance for Multi-Viewer and Digital signage applications. The LHM series monitors offer digital HD-SDI input as well as HDMI and DVI inputs.

↓ XVM Series

The XVM Series provides highly accurate color reproduction as required by the most demanding monitoring applications.

Our most color-accurate LCDs and feature true 10-bit display drivers, high-purity RGB matrix LED backlight system (EEFL for XVM-325W) and TVLogic's most advanced video processing engine.

Industry-leading color management is achieved using the XVM's built-in 3D Look-Up-Table to import/export 3rd party 3D LUTs and precisely reproduce various color gamuts with excellent grayscale linearity.

The XVM supports a full range of HD and SD digital formats including standard Analog, HDMI, DVI input single and dual-link plus 3G-SDI.



↑ RKM Series

Five rack-mountable monitors with 3G-SDI capability and professional features such as Audio Level Meters, Time Code Display, Waveform/Vector Scopes and etc.



TVLogic Monitor Series



← LVM Series

The LVM Series is designed to offer superior picture quality, wide viewing angle and professional broadcast functionality.

Ten sizes and models offer the best solutions from field recording to master monitoring in studio.

LVM series monitors accept most standard input formats and are compatible with a wide range of professional video monitoring requirements.

Slim, single-piece integrated designs, low power consumption, and easy-to-use rack mount kits for 7" - 24" monitors help to meet all your monitoring requirements.

All LVM series models offer various broadcast features including Waveform, Vectorscope, Focus Assist, Embedded Audio Level Meter, Closed Caption, UMD, Markers/Mattes, 1:1 pixel mode and more.



↑ SWM Series

The SWM series monitors are newly designed for the best match for the studio walls. A clean bezel with only a power button and a small indication lamp secures the best monitoring condition for the users.

Along with the traditional interfaces of SDI, HDMI and DVI, the optical fiber interface has been added for the user's choice. It supports video formats up to 3G-SDI and professional features such as Marker, Timecode, Audio Level Meter, various CCs and UMDs.

↓ LUM Series

The LUM series offers four monitors with UHD/4K resolution, precise color reproduction, and wide color gamut. TVLogic introduced one of the 1st generation 4K monitors, the LUM-560W in 2010.

Our latest offerings include a 31" 4K-DCI monitor and 24" and 55" UHD monitors with up to 12G single SDI input.



← LEM Series

TVLogic introduced the world's first AMOLED broadcast monitor in 2010, the LEM-150, a 15" HD resolution OLED monitor that demonstrated the great potential this new display technology can offer for professional motion imaging display.

Our current OLED monitor, the LEM-250A, is the most capable and color-accurate monitor we have built to date.



Viewfinder LCD Monitors

VFM-056WP

TVlogic® Always ON-AIR

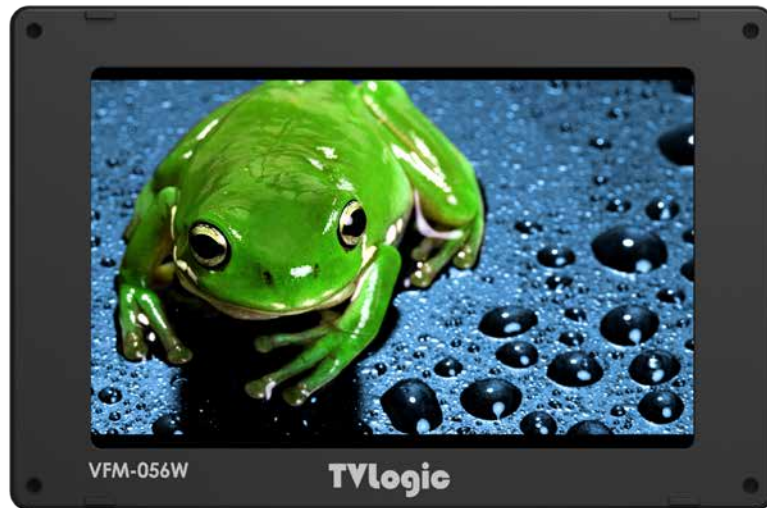

Main body Dimensions

- Main Body : 156 x 103 x 26.5 (mm) / 6.14 x 4.06 x 1.04 (inch)

- Weight : 0.3kg / 0.66lbs

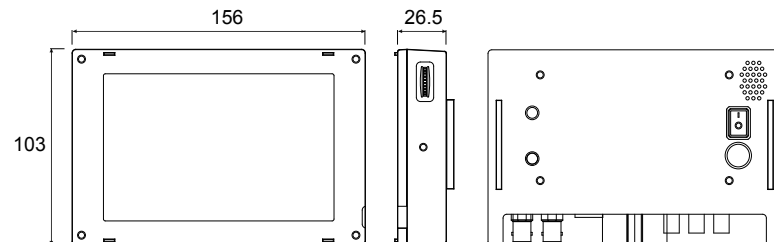

Optional Accessories



5.6" Light Weight Compact Viewfinder

The VFM-056WP is available in two configurations and is ideal for HD-SLR production. A 6"x 4"x 1" lightweight magnesium-alloy case houses a 5.6" 1280x800 LED backlight LCD display with a full complement of preferred features including DSLR Scale, Focus Assist, Various Scan Modes, Markers, Audio Level Meter with speaker, Timecode Display, HDMI loop out via HD-SDI (720p), Waveform/Vectorscope, Y Level Check and Range Error Check.



Product Highlights

- 5.6" 1280x800 (16:10) Resolution
- HDMI to SDI Conversion
- Magnesium Housing + Light Weight
- 3G-SDI Level A/B
- Audio Level Meter Display
- Blue Only
- Luma(Y) Zone Check
- Max Brightness On / Off
- Temperature Adaptive Color
- Time Code Display
- User Aspect
- Various Scan modes
- Waveform/Vectorscope
- Focus Assist
- Marker
- Range Error
- H/V Delay
- Mono
- Zoom

Size	5.6"
Resolution	1280 x 800 (16 : 10)
Pixel Pitch	0.0945mm
Color Depth	16.7M
Viewing Angle (Typ.)	170°(H) / 170°(V)
Luminance (Max.)	300cd/m ² (center)
Contrast Ratio	500:1
Display Area	121(H) × 76(V) mm

Input	
3 x RCA	Analog Video Input
1 x BNC	SDI Channel Input
1 x HDMI	HDMI(1.2Ver) Input

Output	
1x BNC	HDMI-to-SDI conversion output

Input Signal	
Analog	CVBS / S-Video / Component Video
3G-SDI	2.970Gb/s
HD-SDI	1.485Gb/s
SD-SDI	270Mb/s
HDMI	1080p (24/25/30/50/60)/1080i(50/60)/720p (50/60)/480i(60)/480p(60)/576i(50)/576p(50) & VESA/IBM Modes

Analog Input Spec	
CVBS	1.0Vp-p (With Sync) NTSC. PAL
S-Video	1.0Vp-p (Y With Sync), 0.286/0.300 Vp-p (Chroma)

Component Video	1.0Vp-p (Y With Sync), ±350mV (Pb,Pr)
-----------------	---------------------------------------

SDI Input Signal Formats	
SMPTE-425M-A/B	1080p(60/59.94/50/30/29.97/25/24/23.98 /30sF/29.97sF/25sF/24sF/23.98sF) / 1080i (60/59.94/50)
SMPTE-274M	1080i (60/59.94/50) 1080p (30/29.97/25/24/24sF/23.98/23.98sF)
SMPTE-296M	720p (60/59.94/50)
SMPTE-260M	1035i (60/59.94)
SMPTE-125M	480i (59.94)
ITU-R BT.656	576i (50)

Audio In	Embedded Audio
Audio Out	Analog Stereo (Phone Jack) / Internal Speaker (Mixed Mono)
Power	DC 12V/3A (Max 6.0A)
Power Consumption (Approx.)	8.4Watts(Typ.)
Operating Temperature	0°C to 40°C (32°F to 104°F)
Storage Temperature	-20°C to 60°C (-4°F to 140°F)
Accessory	AC Power Cord / DC Power Adaptor / BNC Connector / Camera Mount Support

* Specifications may be changed without notice.

Viewfinder LCD Monitors

VFM-058W



Main body Dimensions

- Main Body : 156 x 98 x 28.5 (mm) / 6.14 x 3.85 x 1.12 (inch)
- Weight : 0.34kg / 0.74lbs (with heatsink : 0.12kg / 0.26lbs)

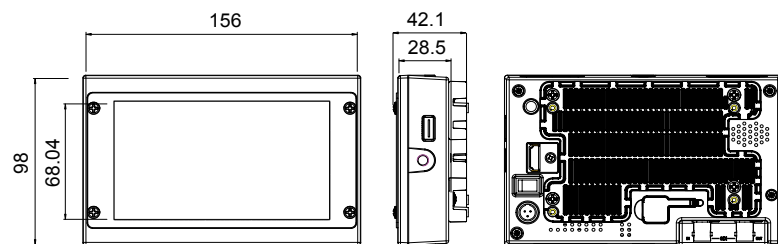

Optional Accessories



5.5" Full HD Viewfinder

The VFM-058W, combines a compact and lightweight form-factor with outstanding picture quality from a 5.5" 1920 x 1080 native LCD.

The VFM-058Ws innovative and ergonomic design makes it ideal for camera-top monitoring. It supports multi-formats including 3G/HD/SD-SDI and HDMI for DSLR cameras, broadcast news and motion picture production.

The VFM-058W has various features such as Max Brightness function, Temperature Adaptive Color, HDMI-to-SDI cross converted output, 1:1 pixel mode, Luma(Y) Zone Check function, DSLR Scale, Waveform/Vectorscope, Range Error, Focus Assist, Markers, Audio Level Meter with speaker and Timecode display.



Product Highlights

- 5.5" 1920x1080 (16:9) Resolution
- HDMI ↔ SDI cross conversion
- Audio Level Meter Display
- Max Brightness On / Off
- Temperature Adaptive Color
- Luma(Y) Zone Check
- Blue Only
- H/V Delay
- Key lock
- Mono
- Time Code Display
- Various Scan modes
- Zoom
- 3G-SDI Level A/B
- Focus Assist
- H/V Flip
- Marker
- Range Error
- User Aspect
- Waveform/Vectorscope
- Camera LUT

Size	5.5"
Resolution	1920 x 1080 (16 : 9)
Pixel Pitch	0.063mm
Color Depth	16.7M
Viewing Angle (Typ.)	160°(H) / 160°(V)
Luminance (Max.)	450cd/m ² (Typ.)
Contrast Ratio	1000:1
Display Area	121(H) × 68(V) mm

Input	
1 x BNC	SDI Input
1 x HDMI	HDMI(1.2Ver) Input
Output	
1x BNC	HDMI-to-SDI conversion output
1x HDMI	HDMI Output, SDI to HDMI conversion output
Input Signal	
3G-SDI	2.970Gb/s
HD-SDI	1.485Gb/s
SD-SDI	270Mb/s
HDMI	1080p (24/25/30/50/60)/1080i(50/60)/720p(50/60)/480i(60)/480p(60)/576i(50)/576p(50) & VESA/IBM Modes
SDI Input Signal Formats	
SMPTE-425M-A/B	1080p (60/59.94/50/30/29.97/25/24/23.98/30sF/29.97sF/25sF/24sF/23.98sF) / 1080i (60/59.94/50)
SMPTE-274M	1080i (60/59.94/50) 1080p (30/29.97/25/24/24sF/23.98/23.98sF)
SMPTE-296M	720p (60/59.94/50)
SMPTE-260M	1035i (60/59.94)
SMPTE-125M	480i (59.94)
ITU-R BT.656	576i (50)
Audio In	
Audio In	Embedded Audio
Audio Out	
Audio Out	Analog Stereo (Phone Jack) / Internal Speaker (Mono)
Power	
Power	DC 12V/3A (Max 6.0A)
Power Consumption (Approx.)	
Power Consumption (Approx.)	9.6Watts(Typ.)
Operating Temperature	
Operating Temperature	0°C to 45°C (32°F to 113°F)
Storage Temperature	
Storage Temperature	-20°C to 60°C (-4°F to 140°F)
Accessory	
Accessory	AC Power Cord / DC Power Adapter / Camera Mount Support / BNC Connector / Acrylic Protector

* Specifications may be changed without notice.

3G-SDI Multi-Channel LCD Rack Monitors

RKM-535A *New!*



Compact 3.5" x 5 Rack Mount Monitor

The RKM-535A is 2RU rack-mount monitor with five high resolution (960 x 640) 8 bit LCDs offering unprecedented image quality in a compact rackmount system.

Features include Focus Assist, Various Scan Modes, Markers, Audio Level Metering, Timecode Display, Closed Captioning, Waveform/Vectorscope, and more.



Main body Dimensions

- Main Body : 480.8 x 87.7 x 118.7 (mm) / 18.93 x 3.45 x 4.67 (inch)
 - Weight : TBD

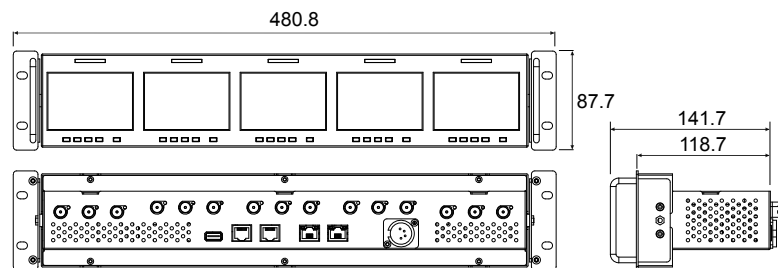

Product Highlights

- 5 x 3.5" LCD Screens
- 960x640 Resolution (3:2)
- High Contrast Ratio of 1000:1
- 1.67 Million Colors (8bit)
- 1:1 Pixel Mapping Modes for SD/HD
- Waveform / Vectorscope
- CC (608, 708, OP42, OP47)
- TVLogic Color Calibration Utility
- 3G-SDI Level A/B
- Audio Level Meter
- Blue Only
- Focus Assist
- H/V Delay
- Key Lock
- Luma Zone Check
- Marker
- Mono
- Range Error
- Time Code Display
- UMD
- User Aspect
- Various Scan Modes
- Waveform / Vectorscope
- Zoom

Size	3.54"
Resolution	940 x 640 (3:2)
Pixel Pitch	0.078mm
Color Depth	16.7M
Viewing Angle(Typ.)	160°(H) / 160°(V)
Luminance (Max.)	500cd/m ² (center)
Contrast Ratio	1000:1
Display Area	75(H)X50(V)mm
Input	
1 x BNC	SDI Channel Input
1 x BNC	Analog Video Input
Output	
1x BNC	SDI Channel Output
Input Signal	
Analog	CVBS
3G-SDI	2.970Gb/s
HD-SDI	1.485Gb/s
SD-SDI	270Mb/s
Analog Input Spec	
CVBS	1.0Vp-p (With Sync) NTSC. PAL
SDI Input Signal Formats	
SMPTE-425M-A/B	1080p(23.98/24/25/30/29.97/25/24/23.98/30sF/29.97sF/25sF/24sF/23.98sF), 1080i(60/59.94/50)
SMPTE-274M	1080p(30/29.97/25/24/24sF/23.98/23.98sF) / 1080i (60/59.94/50)
SMPTE-296M	720p (60/59.94/50)
SMPTE-260M	1035i (60/59.94)
SMPTE-125M	480i (59.94)
ITU-R BT.656	576i (50)
Audio In	-
Audio Out	-
Power	DC 12V
Power Consumption (Approx.)	TBD
Operating Temperature	0°C to 45°C (32°F to 113°F)
Storage Temperature	-20°C to 60°C (-4°F to 140°F)
Accessory	TBD

* Specifications may be changed without notice.

3G-SDI Multi-Channel LCD Rack Monitors

RKM-443A



2RU rack-mount monitor with 4 x 4.3" LCD screens with high luminance of 600cd/m² and reasonable resolution of 800 x 480 for the size. It supports SDI in/out and CVBS video input.

Product Highlights

- 4.3" 800 x 480 (15:9) Resolution
- 1:1 Pixel Mapping Modes for SD/HD/FHD
- 3G-SDI Level A/B
- Audio Level Meter Display
- Blue Only
- Focus Assist
- H/V Delay
- Key lock
- Luma(Y') Zone Check
- Marker
- Mono
- Range Error
- Time Code Display
- UMD
- User Aspect
- Various Scan modes
- Waveform/Vectorscope
- Zoom
- CC-608 LINE 21/ANC, CC-708

Main body Dimensions

- **Main Body** : 480.8 x 87.7 x 100.82 (mm) / 18.93 x 3.45 x 3.97 (inch)
 - **Weight** : 3.4kg / 7.48lbs

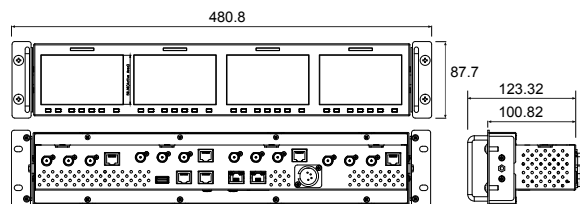

RKM-356A



2RU rack-mount monitor with 3 x 5.6" LCD screens. Utilizing the same high performance LCD found in the VFM-056WP, it offers high resolution (1280 x 800) and wide viewing angle and supports SDI in/out and HDMI input.

Product Highlights

- 5.6" 1280 x 800 (16:10) Resolution
- 1:1 Pixel Mapping Modes for SD/HD/FHD
- 3G-SDI Level A/B
- Audio Level Meter Display
- Blue Only
- Focus Assist
- H/V Delay
- Key lock
- Luma(Y') Zone Check
- Marker
- Mono
- Range Error
- Time Code Display
- UMD
- User Aspect
- Various Scan modes
- Waveform/Vectorscope
- Zoom
- CC-608 LINE 21/ANC, CC-708

Main body Dimensions

- **Main Body** : 480.8 x 87.7 x 72.5 (mm) / 18.93 x 3.45 x 2.85 (inch)
 - **Weight** : 3.9kg / 8.58lbs

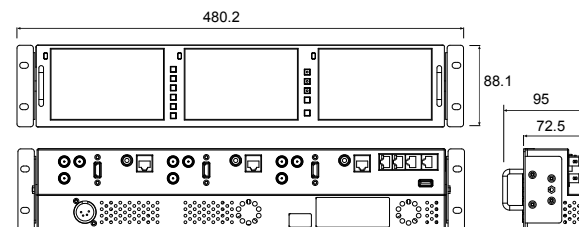

Model	RKM-443A	RKM-356A
Size	4.3"	5.6"
Resolution	800 x 480 (15 : 9)	1280 x 800 (16 : 10)
Pixel Pitch	0.117mm	0.094mm
Color Depth	16.7M	16.7M
Viewing Angle (Typ.)	160°(H) / 160°(V)	170°(H) / 170°(V)
Luminance (Max.)	600cd/m ² (center)	300cd/m ² (center)
Contrast Ratio	1000:1	500:1
Input (1 Screen)		
1 x BNC	SDI Channel Input	-
1 x BNC	CVBS	CVBS
1 x HDMI	-	HDMI Input
2 x BNC	-	SDI A/B Channel Input
Output (1 Screen)		
1 x BNC	SDI Channel Output	SDI Channel Output
Input Signal		
Analog	CVBS	CVBS
3G SDI	2.970Gb/s	2.970Gb/s
HD-SDI	1.485Gb/s	1.485Gb/s
SD-SDI	270Mb/s	270Mb/s
HDMI	-	1080p(24/25/30/50/60) / 1080i(50/60) / 720p(50/60) / 480i(60) / 480p(60) / 576i(50) / 576p(50) & VESA / IBM Modes
SDI Input Signal Formats		
SMPTE-425M-A/B	1080i(60/59.94/50) 1080p(23.98/24/25/30/29.97/25/24/23.98/30sF/29.97sF/25sF/24sF/23.98sF)	1080i(60/59.94/50) 1080p(23.98/24/25/30/29.97/25/24/23.98/30sF/29.97sF/25sF/24sF/23.98sF)
SMPTE-274M	1080i (60 / 59.94 / 50) 1080P (30/29.97/25/24/24sF/23.98/23.98sF)	1080i (60/59.94/50) 1080p(30/29.97/25/24/24sF/23.98/23.98sF)
SMPTE-296M	720p(60/59.94/50)	720p(60/59.94/50)
SMPTE-260M	1035i(60/59.94)	1035i(60/59.94)
SMPTE-125M	480i(59.94)	480i(59.94)
ITU-R BT.656	576i(50)	576i(50)
Power	DC 12V / 3A (Max 6.0A)	DC 12V / 3A (Max 6.0A)
Power Consumption (Approx.)	60Watts(Typ.)	60Watts(Typ.)
Operating Temperature	0°C to 40°C (32°F to 104°F)	0°C to 45°C (32°F to 113°F)
Storage Temperature	-20°C to 60°C (-4°F to 140°F)	-20°C to 60°C (-4°F to 140°F)
Accessory	AC Power Cord, Rack Mountable Kit	AC Power Cord, Rack Mountable Kit

* Specifications may be changed without notice.

3G-SDI Multi-Channel LCD Rack Monitors

RKM-270A

RKM-290A



3RU rack-mount monitor with 2 x 7" 1024 x 600 resolution wide viewing angle IPS LCD screens as found in which has the same high performance display as LVM-074W. It supports SDI in/out and HDMI input.

4RU rack-mount monitor with 2 x 9" 1920 x 1080 LCD screens. utilizing the the same high performance display found in the LVM-095W-N with full HD resolution and wide viewing angle capability. It supports SDI in/out and HDMI input.

Product Highlights

- 7" 1024 x 600 (16:9) Resolution
- 1:1 Pixel Mapping Modes for SD/HD/FHD
- 3G-SDI Level A/B
- Audio Level Meter Display
- Blue Only
- Focus Assist
- Key lock
- Marker
- Range Error
- Time Code Display
- UMD
- Various Scan modes
- H/V Delay
- Luma(Y') Zone Check
- Mono
- Zoom
- User Aspect
- CC-608 LINE 21/ANC, CC-708
- Waveform/Vectorscope

Main body Dimensions

- **Main Body** : 480.8 x 132 x 50.5 (mm) / 18.93 x 5.2 x 1.99 (inch)
 - **Weight** : 4kg / 8.8lbs

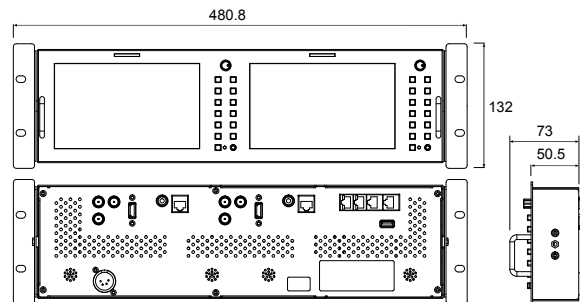

Product Highlights

- 9" 1920 x 1080 (16:9) Resolution
- 1:1 Pixel Mapping Modes for SD/HD/FHD
- Audio Level Meter Display
- 3G-SDI Level A/B
- Focus Assist
- Key lock
- Marker
- Range Error
- Time Code Display
- UMD
- Various Scan modes
- Blue Only
- H/V Delay
- Luma(Y') Zone Check
- Mono
- Zoom
- User Aspect
- CC-608 LINE 21/ANC, CC-708
- Waveform/Vectorscope

Main body Dimensions

- **Main Body** : 480.2 x 175 x 47.4 (mm) / 18.91 x 6.89 x 1.87 (inch)
 - **Weight** : 4.9kg / 10.78lbs

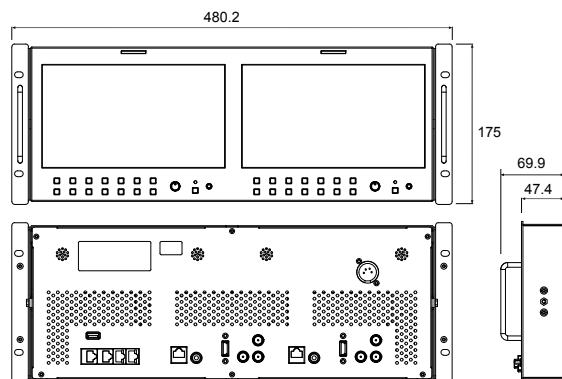

Model	RKM-270A	RKM-290A
Size	7"	9"
Resolution	1024 x 600 (16 : 9)	1920 x 1080 (16 : 9)
Pixel Pitch	0.15mm	0.103mm
Color Depth	16.7M	16.7M
Viewing Angle (Typ.)	160°(H) / 160°(V)	176°(H) / 176°(V)
Luminance (Max.)	400cd/m ² (center)	400cd/m ² (center)
Contrast Ratio	800:1	750:1
Input (1 Screen)		
1 x HDMI	HDMI Input	HDMI Input
2 x BNC	SDI A/B Channel Input	SDI A/B Channel Input
1 x BNC	CVBS	CVBS
Output (1 Screen)		
1 x BNC	SDI Selected Channel Output	SDI Selected Channel Output
Input Signal		
Analog	CVBS	CVBS
3G-SDI	2.970Gb/s	2.970Gb/s
HD-SDI	1.485Gb/s	1.485Gb/s
SD-SDI	270Mb/s	270Mb/s
HDMI	1080P(24/25/30/50/60) / 1080i(50/60) / 720p(50/60) / 480i(60) / 480p(60) / 576i(50) / 576p(50)	1080p(24/25/30/50/60) / 1080i(50/60) / 720p(50/60) / 480i(60) / 480p(60) / 576i(50) / 576p(50) / 640x480 / 720x400 / 800x600 / 1024x768 / 280x1024 / 1366x768
SDI Input Signal Formats		
SMPT-425M-A/B	1080i(60/59.94/50) 1080p(23.98/24/25/30/29.97/25/24/23.98/30sF/29.97sF/25sF/24sF/23.98sF)	1080i(60/59.94/50) 1080P(60/59.94/50/30/29.97/25/24/23.98/30sF/29.97sF/25sF/24sF/23.98sF)
SMPT-274M	1080i(60/59.94/50) 1080P(30/29.97/25/24/24sF/23.98/23.98sF)	1080i(60/59.94/50) 1080P(30/29.97/25/24/24sF/23.98/23.98sF)
SMPT-296M	720p(60/59.94/50)	720p(60/59.94/50)
SMPT-260M	1035i(60/59.94)	1035i(60/59.94)
SMPT-125M	480i(59.94)	480i(59.94)
ITU-R BT.656	576i(50)	576i(50)
2K Format	-	2048x1080p(24/24sF/23.98/23.98sF)
Audio IN	Embedded Audio / Analog stereo (Phone Jack)	Embedded Audio / Analog stereo (Phone Jack)
Audio OUT	Analog stereo (Phone Jack) / Internal Speaker (Mixed Mono)	Analog stereo (Phone Jack) / Internal Speaker (Mixed Mono)
Power	DC 12/24V	DC 12/24V
Power Consumption (Approx.)	60Watts(Typ.)	60Watts(Typ.)
Operating Temperature	0°C to 35°C (32°F to 95°F)	0°C to 45°C (32°F to 113°F)
Storage Temperature	-20°C to 60°C (-4°F to 140°F)	-20°C to 60°C (-4°F to 140°F)
Accessory	TBD	TBD
Optional Accessories	TBD	TBD

LVM-070C *New!*



Main body Dimensions

- Main Body : 203 x 131 x 34.6 (mm) / 8 x 5.16 x 1.36 (inch)
- With stand : 240 x 146 x 69 (mm) / 9.44 x 5.74 x 2.72 (inch)
- Weight : 0.9kg / 1.98lbs

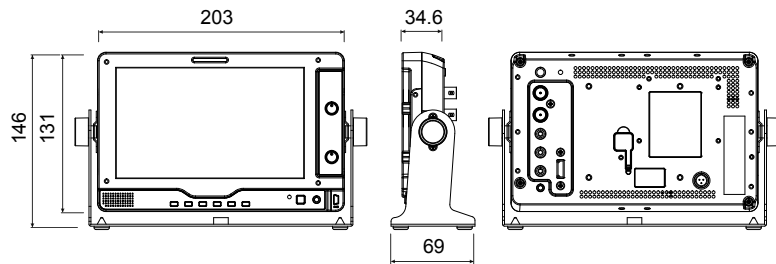

Optional Accessories



7" Field monitors

The LVM-070C offers TVLogic quality, reliability and pro features at a lower price-point. With a high resolution 1024 x 600 (16:9) 7 inch LCD display, the LVM-070C accommodates multi-format digital 3G/HD/SD-SDI and HDMI signals as well as analog inputs. The many features of the LVM-070C include Waveform/vectorscope, Focus Assist, Log to Linear conversion LUT, audio level meters and more.



Product Highlights

- 7" 1024 x 600 (16:9) Resolution
- White LED Backlight
- 1:1 Pixel Mapping Modes for SD/HD/FHD
- 3G-SDI Level A/B
- Audio Level Meter Display
- Blue Only
- Focus Assist
- Luma(Y) Zone Check
- Marker
- Max Brightness On / Off
- Mono
- Range Error
- Temperature Adaptive Color
- Time Code Display
- User Aspect
- Various Scan modes
- Waveform/Vectorscope
- Zoom
- Camera LUT

Size	7"
Resolution	1024 x 600 (16:9)
Pixel Pitch	0.15mm
Color Depth	16.7M
Viewing Angle (Typ.)	160°(H)/160°(V)
Luminance (Max.)	400cd/m ²
Contrast Ratio	900:1
Display Area	153(H)X90(V)mm

Input	
1 x HDMI	HDMI Input
3 x RCA	Analog Video Input
1 x BNC	SDI 1 Channel Input
Output	
1 x BNC	SDI Channel Output (Loop Through Out)
Input Signal	
Analog	CVBS / S-Video / Component Video
3G-SDI	2.97Gb/s
HD-SDI	1.485Gb/s
SD-SDI	270Mb/s
HDMI	1080p (24/25/30/50/60)/1080i(50/60)/ 720p (50/60)/480i(60)/480p(60)/576i(50)/576p(50)
Analog Input Spec	
CVBS	1.0Vp-p (With Sync) NTSC. PAL
S-Video	1.0Vp-p (Y With Sync), 0.286/0.300 Vp-p (Chroma)
Component Video	1.0Vp-p (Y With Sync), ±350mV (Pb,Pr)
SDI Input Signal Formats	
SMPTE-425M-A/B	1080p (60/59.94/50/30/29.97/25/24/23.98/30sF/29.97sF/25sF/24sF/23.98sF) / 1080i (60/59.94/50)
SMPTE-274M	1080i (60/59.94/50) 1080p (30/29.97/25/24/24sF/23.98/23.98sF)
SMPTE-296M	720p (60/59.94/50)
SMPTE-260M	1035i (60/59.94)
SMPTE-125M	480i (59.94)
ITU-R BT.656	576i (50)
Audio IN	Embedded Audio / Analog stereo (Phone Jack)
Audio OUT	Analog stereo (Phone Jack) / Internal Speaker (Mixed Mono)
Power	DC 12V
Power Consumption (Approx.)	20Watts(Max)
Operating Temperature	0°C to 40°C (32°F to 104°F)
Storage Temperature	-20°C to 60°C (-4°F to 140°F)
Accessory	AC Power Cord / DC Power Adaptor / Camera Mount Support / Stand

* Specifications may be changed without notice.

LVM-075A *New!*



Main body Dimensions

- Main Body : 203 x 131 x 34.6 (mm) / 8 x 5.16 x 1.36 (inch)
- With stand : 240 x 146 x 69 (mm) / 9.44 x 5.74 x 2.72 (inch)
- Weight : 1.04kg / 2.29lbs

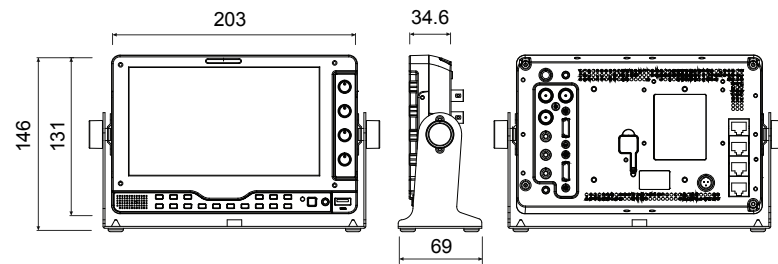

Optional Accessories



7" FHD monitors

The LVM-075A is the sharpest and most color-accurate 7" monitor available today. With an upgraded 1920 x 1080 LCD module, the LVM-075A supports C-Log/S-Log 1, 2 & 3 and RED Gammas 3&4 conversion to Rec.709 color gamut and includes Waveform/Vector Scope, Focus Assist, Audio Level Meters, UMD and Closed Captioning and more.



Product Highlights

- 7" 1920 x 1080 (16:9) Resolution
- White LED Backlight
- 1:1 Pixel Mapping Modes for SD/HD/FHD
- 3G-SDI Level A/B
- Audio Level Meter Display
- Blue Only
- Focus Assist
- H/V Delay
- H/V Flip
- Luma(Y) Zone Check
- Marker
- Max Brightness On / Off
- Temperature Adaptive Color
- Time Code Display
- Various Scan modes
- Waveform/Vectorscope
- CC-608 LINE 21/ANC, CC-708
- Mono
- User Aspect
- Camera LUT
- Range Error
- Zoom

Size	7"
Resolution	1920X1080 (16:9)
Pixel Pitch	0.081mm
Color Depth	16.7M
Viewing Angle (Typ.)	170°(H)/170°(V)
Luminance (Max.)	600cd/m ²
Contrast Ratio	800:1
Display Area	155(H) X 87(V)mm

Input	
1 x HDMI	HDMI Input
3 x RCA	Analog Video Input
2 x BNC	SDI 2 Channel Input
Output	
1 x BNC	SDI Channel Output (Loop Through Out) / HDMI to SDI conversion output
1 x HDMI	HDMI (Loop Through Out)
Input Signal	
Analog	CVBS / S-Video / Component Video
3G-SDI	2.97Gb/s
HD-SDI	1.485Gb/s
SD-SDI	270Mb/s
HDMI	1080p (24/25/30/50/60)/1080i(50/60)/720p (50/60)/480i(60)/480p(60)/576i(50)/576p(50)
Analog Input Spec	
CVBS	1.0Vp-p (With Sync) NTSC. PAL
S-Video	1.0Vp-p (Y With Sync), 0.286/0.300 Vp-p (Chroma)
Component Video	1.0Vp-p (Y With Sync), ±350mV (Pb,Pr)
SDI Input Signal Formats	
SMPTE-425M-A/B	1080p (60/59.94/50/30/29.97/25/24/23.98/30sF/29.97sF/25sF/24sF/23.98sF) / 1080i (60/59.94/50)
SMPTE-274M	1080i (60/59.94/50) 1080p (30/29.97/25/24/24sF/23.98/23.98sF)
SMPTE-296M	720p (60/59.94/50)
SMPTE-260M	1035i (60/59.94)
SMPTE-125M	480i (59.94)
ITU-R BT.656	576i (50)
Audio IN	Embedded Audio / Analog stereo (Phone Jack)
Audio OUT	Analog stereo (Phone Jack) / Internal Speaker (Mixed Mono)
Power	DC 12V
Power Consumption (Approx.)	20Watts(Max)
Operating Temperature	0°C to 40°C (32°F to 104°F)
Storage Temperature	-20°C to 60°C (-4°F to 140°F)
Accessory	AC Power Cord / DC Power Adaptor / Camera Mount Support / Stand

* Specifications may be changed without notice.

Sunlight Readable Monitor

SRM-074W-N



Main body Dimensions

- Main Body : 203 x 131 x 34.6 (mm) / 8 x 5.16 x 1.36 (inch)
- With stand : 240 x 143 x 69 (mm) / 9.44 x 5.63 x 2.72 (inch)
- Weight : 0.94kg / 2.07lbs

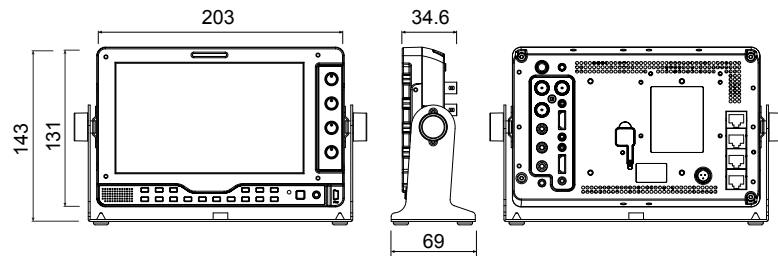

Optional Accessories



The Most Comprehensive 7" HD LCD Display Available

The SRM-074W-N features a high-resolution (1024x600) 7" LED backlit LCD panel housed in lightweight (600 grams) yet durable magnesium alloy case.

An ideal monitor for the latest compact cinema cameras, the SRM-074W-N offers a wide range of professional features including: Waveform/Vectorscope, built-in HDMI to HD-SDI conversion output, Horizontal and Vertical Image Flip, Focus Assist, Audio Level Meter and more.

A feature unique to the SRM-074W-N is TVLogic's new user selectable Temperature Adaptive Color function that measures LCD panel temperature and automatically compensates the white balance drift caused by a cold or hot weather.



Product Highlights

- 7" 1024 x 600 (16:9) Resolution
- 1500 NWhite LED Backlight
- 1:1 Pixel Mapping Modes for SD/HD/FHD
- Temperature Adaptive Color
- Waveform/Vectorscope
- Audio Level Meter Display
- Focus Assist
- Max Brightness On / Off
- Time Code Display
- Various Scan modes
- H/V Flip
- CC-608 LINE 21/ANC, CC-708
- Zoom
- 3G-SDI Level A/B
- Blue Only
- Luma(Y') Zone Check
- Marker
- User Aspect
- H/V Delay
- Mono
- Range Error

Size	7"
Resolution	1024 x 600 (16:9)
Pixel Pitch	0.15mm
Color Depth	16.7M
Viewing Angle (Typ.)	160°(H)/160°(V)
Luminance (Max.)	1500cd/m²
Contrast Ratio	800:1
Display Area	154(H) X 90(V)mm

Input	
1 x HDMI	HDMI Input
3 x RCA	Analog Video Input
2 x BNC	SDI 2 Channel Input
Output	
1 x BNC	SDI Channel Output (Loop Through Out) / HDMI to SDI conversion output
1 x HDMI	HDMI (Loop Through Out)
Input Signal	
Analog	CVBS / S-Video / Component Video
3G-SDI	2.97Gb/s
HD-SDI	1.485Gb/s
SD-SDI	270Mb/s
HDMI	1080p (24/25/30/50/60)/1080i(50/60)/720p (50/60)/480i(60)/480p(60)/576i(50)/576p(50)
Analog Input Spec	
CVBS	1.0Vp-p (With Sync) NTSC. PAL
S-Video	1.0Vp-p (Y With Sync), 0.286/0.300 Vp-p (Chroma)
Component Video	1.0Vp-p (Y With Sync), ±350mV (Pb,Pr)
SDI Input Signal Formats	
SMPTE-425M-A/B	1080p (60/59.94/50/30/29.97/25/24/23.98/30sF/29.97sF/25sF/24sF/23.98sF) / 1080i (60/59.94/50)
SMPTE-274M	1080i (60/59.94/50) 1080p (30/29.97/25/24/24sF/23.98/23.98sF)
SMPTE-296M	720p (60/59.94/50)
SMPTE-260M	1035i (60/59.94)
SMPTE-125M	480i (59.94)
ITU-R BT.656	576i (50)
Audio IN	
	Embedded Audio / Analog stereo (Phone Jack)
Audio OUT	
	Analog stereo (Phone Jack) / Internal Speaker (Mixed Mono)
Power	
	DC 12V/1A (Max 2.0A)
Power Consumption (Approx.)	
	10Watts(Typ.)
Operating Temperature	
	0°C to 40°C (32°F to 104°F) / 0°C to 35°C (32°F to 95°F) (SRM-074W)
Storage Temperature	
	-20°C to 60°C (-4°F to 140°F)
Accessory	
	AC Power Cord / DC Power Adaptor / Camera Mount Support / Stand

* Specifications may be changed without notice.

LVM-095W-N



Multi Format | 16

Main body Dimensions

- Main Body : 223 x 175 x 60 (mm) / 8.78 x 6.89 x 2.36 (inch)
- With stand : 260 x 194.2 x 90 (mm) / 10.24 x 7.65 x 3.54 (inch)
- Weight : 2.1Kg / 4.63lbs

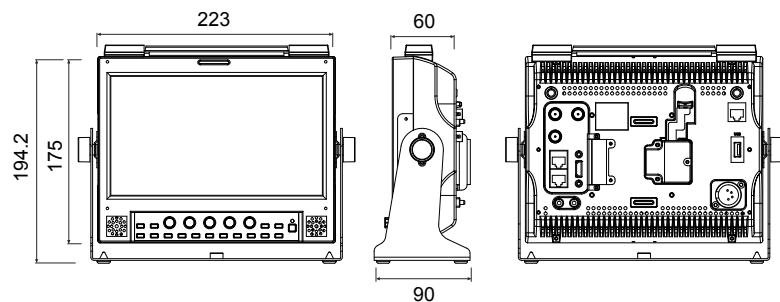

Optional Accessories



9" FHD Multi-purpose Monitor

The LVM-095W-N is the new 9" released from TVLogic displays full HD resolution of 1920x1080. It also corresponds with a wide range of image sources (3G HD/SD-SDI, HDMI) and provides a wide viewing angle (176 degrees).

For maximized efficiency and economic feasibility, LVM-095W-N is constructed from aluminum for an extra-light body weight and a holds a built-in V-Mount.

Upgraded with new FHD panel with accurate color reproduction capability that exactly meets the HDTV standards, LVM-095W-N gives super clear picture quality with powerful features.

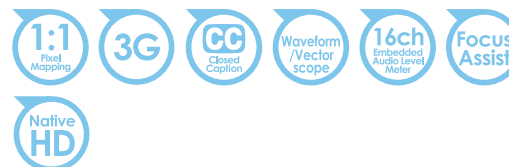

Product Highlights

- 9" 1920 x 1080 (16:9) Resolution
- Temperature Adaptive Color
- 3G-SDI Level A/B
- Luma(Y) Zone Check
- Various Scan modes
- Blue Only
- H/V Delay
- Key lock
- Mono
- UMD
- Zoom
- CC-608 LINE 21/ANC, CC-708
- Audio Level Meter Display
- Time Code Display
- Waveform/Vectorscope
- Focus Assist
- H/V Flip
- Marker
- Range Error
- User Aspect
- Camera LUT

Size	9"
Resolution	1920 x 1080 (16 : 9)
Pixel Pitch	0.1035mm
Color Depth	16.7M
Viewing Angle (Typ.)	176°(H) / 176°(V)
Luminance (Max.)	400cd/m ²
Contrast Ratio	750:1
Display Area	198(H) x 111(V) mm

Input	
2 x BNC	SDI A/B Channel Input
1 x HDMI	HDMI 1 Input
Output	
1 x BNC	SDI A/B Selected Channel Output / HDMI to SDI conversion output
Input Signal	
Analog	CVBS (SDI B port select)
3G-SDI	2.970Gb/s
HD-SDI	1.485Gb/s
SD-SDI	270Mb/s
HDMI (PC & HDMI mode)	1080p (23.98/24/25/30/50/59.94/60)/1080i (50/59.94/60)/720p(50/60)/480i(60)/480p (60)/576i(50)/576p(50)/640x480/720x400/800x600/1024x768/1280x768/1280x1024/1366x768
Analog Input Spec	
CVBS	1.0Vp-p (With Sync) NTSC. PAL
SDI Input Signal Formats	
SMPTE-425M-A/B	1080p (60/59.94/50/30/29.97/25/24/23.98/30sF/29.97sF/25sF/24sF/23.98sF)
SMPTE-274M	1080i (60 / 59.94 / 50) 1080p (30/29.97/25/24/24sF/23.98/23.98sF)
SMPTE-296M	720p (60/59.94/50)
SMPTE-260M	1035i (60/59.94)
SMPTE-125M	480i (59.94)
ITU-R BT.656	576i (50)
2K Format	2048 x 1080p (24/24sF/23.98/23.98sF)
Audio IN	Embedded Audio / Analog stereo (Phone Jack)
Audio OUT	Analog stereo (Phone Jack) / Internal Speaker (Mixed Mono)
Power	DC 12/24V
Power Consumption (Approx.)	DC 24 Watts (Max 2A)
Operating Temperature	0°C to 45°C (32°F to 113°F)
Storage Temperature	-20°C to 60°C (-4°F to 140°F)
Accessory	AC Power Cord / DC Power Adaptor / Camera Mount Support / Handle / Stand

* Specifications may be changed without notice.

SD/HD/3G-SDI Multi-Format Monitors

LVM-170A



17" FHD Multi-purpose Monitor

The LVM-170A is the Full HD version of TVLogic's 17inch monitoring solutions. This unit features a true 16:9 aspect ratio LCD panel with 1920x1080 resolution and 12-bit video processing performance allowing for faithful color reproduction and video scaling performance.

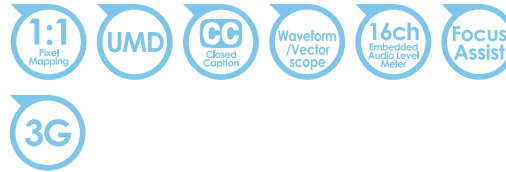

Product Highlights

- 17" 1920x1080 (16:9) Resolution
- 3G-SDI Level A/B
- Audio Level Meter Display
- Blue Only
- Focus Assist
- H/V Delay
- Key lock
- Luma(Y) Zone Check
- Marker
- Mono
- Range Error
- Time Code Display
- UMD
- User Aspect
- Various Scan modes
- Waveform/Vectorscope
- CC-608 LINE 21/ANC, CC-708
- TVLogic Color Calibration Utility
- LKFS Audio Loudness
- Level Meter

Main body Dimensions

- Main Body : 421.5 x 264 x 74.1 (mm) / 16.59 x 10.39 x 2.91 (inch)
- With stand : 483.5 x 310.3 x 137.5 (mm) / 19.03 x 12.2 x 5.41 (inch)
- Weight : 4.2kg / 9.26lbs

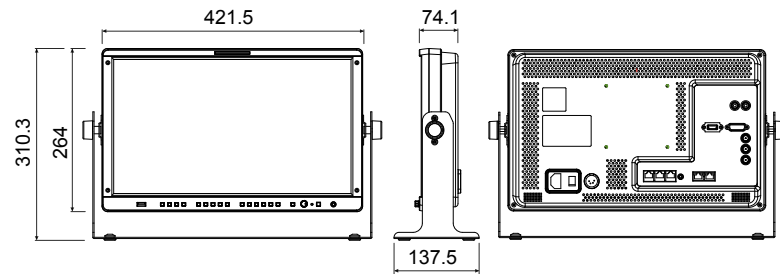

Optional Accessories



Size	17.3"
Resolution	1920 x 1080 (16 : 9)
Pixel Pitch	0.199mm
Color Depth	16.7M
Viewing Angle (Typ.)	178°(H) / 178°(V)
Luminance (Max.)	300cd/m ² (center)
Contrast Ratio	700:1
Display Area	381(H) x 214(V) mm

Input	
1 x BNC	CVBS
2 x BNC	SDI A/B Channel Input
1 x HDMI	HDMI Input
1 x DVI - I	DVI Input

Output	
1 x BNC	CVBS
1 x BNC	SDI A/B Selected Channel Output (Loop Through Out)

Input Signal	
Analog	CVBS
3G-SDI	2.970Gb/s
HD-SDI	1.485Gb/s
SD-SDI	270Mb/s
DVI-Analog	640x480/720x400/800x600/1024x768/1280x1024/1366x768
DVI-D (PC & HDMI)	640x480/720x400/800x600/1024x768/1280x768/1280x1024/1366x768/1080p(23.98/24/25/30/50/60)/1080i(50/59.94/60)/720p(50/60)/480i(60)/480p(60)/576i(50)/576p(50)
HDMI (PC & HDMI)	640x480/720x400/800x600/1024x768/1280x768/1280x1024/1366x768/1080p(23.98/24/25/30/50/60)/1080i(50/59.94/60)/720p(50/60)/480i(60)/480p(60)/576i(50)/576p(50)

Analog Input Spec	
CVBS	1.0Vp-p (With Sync) NTSC. PAL

SDI Input Signal Formats	
SMPTE-425M-A/B	1080p(60/59.94/50/30/29.97/25/24/23.98/30sF/29.97sF/25sF/24sF/23.98sF)1080i(60/59.94/50)
SMPTE-274M	1080i(60/59.94/50)/1080p(30/29.97/25/24/24sF/23.98/23.98sF)
SMPTE-296M	720p (60/59.94/50)
SMPTE-260M	1035i (60/59.94)
SMPTE-125M	480i (59.94)
ITU-R BT.656	576i (50)
2K Format	2048 x 1080p (24/24sF/23.98/23.98sF)
Audio IN	Embedded Audio / Analog stereo (Phone Jack)
Audio OUT	Analog stereo (Phone Jack) Internal Speaker (Stereo)
Power	DC 12/24V / AC 100~240V (50~60Hz)
Power Consumption (Approx.)	60Watts
Operating Temperature	0°C to 40°C (32°F to 104°F)
Storage Temperature	-20°C to 60°C (-4°F to 140°F)
Accessory	AC Power Cord / Stand / USB Cover

* Specifications may be changed without notice.

LVM-171A *Coming Soon!*



Main body Dimensions

- Main Body : 445 x 264 x 78.4 (mm) / 17.52 x 10.39 x 3.09 (inch)
- With stand : 492.2 x 289 x 137.5 (mm) / 19.38 x 11.38 x 5.41 (inch)
- Weight : TBD

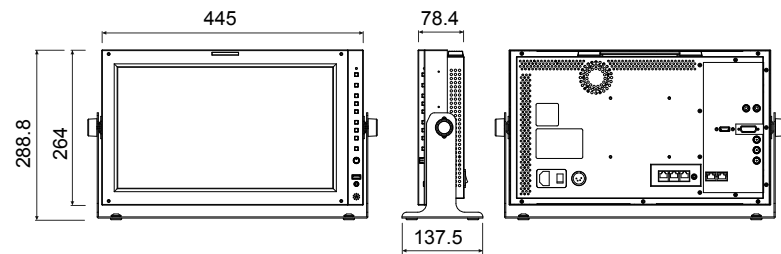

Optional Accessories



A multi-purpose 17" Full HD Monitoring Solution

The LVM-171A is the Full HD version of TVLogic's 17inch monitoring solutions. This unit features a true 16:9 aspect ratio LCD panel with 1920x1080 resolution and 12-bit video processing performance allowing for faithful color reproduction and video scaling performance.

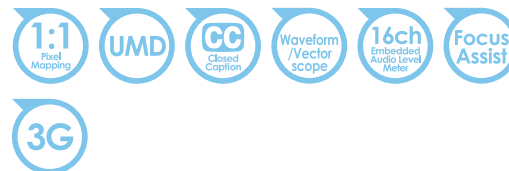

Product Highlights

- 17" 1920x1080 (16:9) Resolution
- 3G-SDI Level A/B
- Audio Level Meter Display
- Blue Only
- Focus Assist
- H/V Delay
- Key lock
- Luma('Y') Zone Check
- Various Scan modes
- Waveform/Vectorscope
- TVLogic Color Calibration Utility
- Marker
- CC-608 LINE 21/ANC, CC-708
- Mono
- Time Code Display
- User Aspect
- Range Error
- UMD

Size	16.5"
Resolution	1920 x 1080 (16 : 9)
Pixel Pitch	0.1905mm
Color Depth	1.07B
Viewing Angle (Typ.)	178°(H) / 178°(V)
Luminance (Max.)	450cd/m ² (center)
Contrast Ratio	1400:1
Display Area	366(H) x 206(V) mm

Input	
1 x BNC	CVBS
2 x BNC	SDI A/B Channel Input
1 x HDMI	HDMI Input
1 x DVI - I	DVI Input

Output	
1 x BNC	CVBS
1 x BNC	SDI A/B Selected Channel Output (Loop Through Out)

Input Signal	
Analog	CVBS
3G-SDI	2.970Gb/s
HD-SDI	1.485Gb/s
SD-SDI	270Mb/s
DVI-Analog	640x480/720x400/800x600/1024x768/1280x1024/1366x768
DVI-D (PC & HDMI)	640x480/720x400/800x600/1024x768/1280x768/1280x1024/1366x768/1080p(23.98/24/25/30/50/60)/1080i(50/59.94/60)/720p(50/60)/480i(60)/480p(60)/576i(50)/576p(50)
HDMI (PC & HDMI)	640x480/720x400/800x600/1024x768/1280x768/1280x1024/1366x768/1080p(23.98/24/25/30/50/60)/1080i(50/59.94/60)/720p(50/60)/480i(60)/480p(60)/576i(50)/576p(50)

Analog Input Spec	
CVBS	1.0Vp-p (With Sync) NTSC. PAL

SDI Input Signal Formats	
SMPTE-425M-A/B	1080p(60/59.94/50/30/29.97/25/24/23.98/30sF/29.97sF/25sF/24sF/23.98sF)/1080i(60/59.94/50)
SMPTE-274M	1080i(60/59.94/50)/1080p(30/29.97/25/24/24sF/23.98/23.98sF)
SMPTE-296M	720p (60/59.94/50)
SMPTE-260M	1035i (60/59.94)
SMPTE-125M	480i (59.94)
ITU-R BT.656	576i (50)
2K Format	2048 x 1080p (24/24sF/23.98/23.98sF)
Audio IN	Embedded Audio / Analog stereo (Phone Jack)
Audio OUT	Analog stereo (Phone Jack) Internal Speaker (Stereo)
Power	DC 12/24V / AC 100~240V (50~60Hz)
Power Consumption (Approx.)	60Watts
Operating Temperature	0°C to 40°C (32°F to 104°F)
Storage Temperature	-20°C to 60°C (-4°F to 140°F)
Accessory	AC Power Cord / Stand / USB Cover

* Specifications may be changed without notice.

SD/HD/3G-SDI Multi-Format Monitors

LVM-182W-A



Main body Dimensions

- Main Body : 442.5 x 309.2 x 65.4 (mm) / 17.42 x 12.17 x 2.57 (inch)
- With stand : 482.5 x 333.4 x 137.6 (mm) / 19.03 x 13.13 x 5.41 (inch)
- Weight : 5.12kg / 11.28lbs

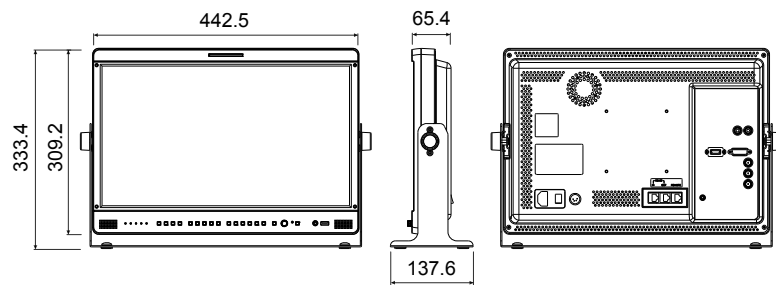

Optional Accessories



The only 18.5" broadcast monitor with true wide viewing angle

The LVM-182W-A is a versatile and cost-effective monitor that supports various video formats including 3G-SDI and professional features. Utilizing the state-of-the-art IPS LCD panel and combined with TVLogic's excellent video processing technology, the LVM-182W-A provides outstanding viewing angle with accurate colors and rich professional features.



Product Highlights

- 18.5" 1366 x 768 (16:9) Resolution
- 3G-SDI Level A/B
- Audio Level Meter Display
- Blue Only
- Focus Assist
- H/V Delay
- Luma(Y) Zone Check
- Marker
- Mono
- Time Code Display
- Various Scan modes
- Waveform/Vectorscope
- TVLogic Color Calibration Utility
- CC-608 LINE 21/ANC, CC-708
- UMD
 - Range Error
- User Aspect
 - X3 Zoom(PBP)
- Zoom

Size	18.5"
Resolution	1366 x 768 (16 : 9)
Pixel Pitch	0.300mm
Color Depth	16.7M
Viewing Angle (Typ.)	178°(H) / 178°(V)
Luminance (Max.)	250cd/m ² (center)
Contrast Ratio	1000:1
Display Area	410(H) x 230(V) mm

Input	
1 x BNC	Analog Input (CVBS)
2 x BNC	3G SDI A/B Channel Input
1 x HDMI	HDMI Input
1 x DVI - I	DVI Input

Output	
1 x BNC	Analog Output (CVBS)
1 x BNC	SDI A/B Selected Channel Output (Active Loop Through)

Input Signal	
Analog (Composite)	CVBS
3G-SDI	2.970Gb/s
HD-SDI	1.485Gb/s
SD-SDI	270Mb/s
DVI-Analog	640x480/720x400/800x600/1024x768/1280x1024/1366x768/1920x1080
DVI-D (PC & HDMI)	640x480/720x400/800x600/1024x768/1280x768/1280x1024/1366x768/1080p(24/25/30/50/60)/1080i(50/60)/720p(50/60)/480i(60)/480p(60)/576i(50)/576p(50)
HDMI (PC & HDMI)	640x480/720x400/800x600/1024x768/1280x768/1280x1024/1366x768/1080p(24/25/30/50/60)/1080i(50/60)/720p(50/60)/480i(60)/480p(60)/576i(50)/576p(50)

Analog Input Spec	
CVBS	1.0Vp-p (With Sync) NTSC. PAL

SDI Input Signal Formats	
SMPTE-425M-A/B	1080p(60/59.94/50/30/29.97/25/24/23.98/30sF/29.97sF/25sF/24sF/23.98sF) 1080i(60/59.94/50)
SMPTE-274M	1080i(60/59.94/50)/1080p(30/29.97/25/24/24sF/23.98/23.98sF)
SMPTE-296M	720p (60/59.94/50)
SMPTE-260M	1035i (60/59.94)
SMPTE-125M	480i (59.94)
ITU-R BT.656	576i (50)

Audio IN	Embedded Audio / Analog stereo (Phone Jack)
Audio OUT	Analog stereo (Phone Jack) / Internal Speaker (Stereo)
Power	DC 24V / DC 12V with V-Mount-182 / AC 100 ~240V (50~ 60 Hz)
Power Consumption (Approx.)	60Watts
Operating Temperature	0°C to 40°C (32°F to 104°F)
Storage Temperature	-20°C to 60°C (-4°F to 140°F)
Accessory	AC Power Cord / Stand

* Specifications may be changed without notice.

SD/HD/3G-SDI Multi-Format Monitors

LVM-212W



21.5" 1920x1080 Rack-Mount Monitor

The LVM-212W is an ideal full HD rack-mount monitor for control rooms and OB Vans. The slim matte finish bezel design fits perfectly into a 19" rack and features a 21.5" native 1920x1080 LED backlit LCD, Dual Channel 3G-SDI input, Waveform/Vectorscope, Closed Caption 608/708, Embedded Audio Metering, wide viewing angle and more.

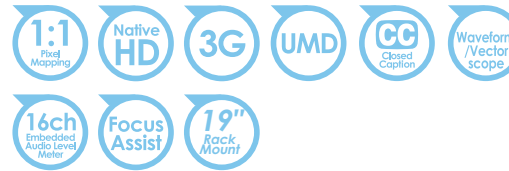

Input	
1 x DVI-I	DVI Input
1 x HDMI	HDMI(1.3Ver) Input
3 x BNC	CVBS Input
2 x BNC	SDI A/B Channel Input

Output	
3 x BNC	Analog (Loop Through Out)
1 x BNC	SDI A/B Selected Channel Output (Loop Through Out)

Input Signal	
Analog	CVBS / S-Video / Component
3G-SDI	2.970Gb/s
HD-SDI	1.485Gb/s
SD-SDI	270Mb/s
HDMI	480i/480p/576i/576p/720p/1080i/1080p (24/25/30/50/60)
DVI-Analog	640x480/720x400/800x600/1024x768/1280x1024/1600x1200
DVI-D (PC mode)	640x480/720x400/800x600/1024x768/1280x1024/1366x768/1600x1200/1920x1200
DVI-D (HDMI mode)	1080p (24/25/30/50/60)/1080i(50/60)/720p (50/60)/480i(60)/480p(60)/576i(50)/576p(50)

Analog Input Spec	
CVBS	1.0Vp-p (With Sync) NTSC. PAL
S-Video	1.0Vp-p (Y With Sync), 0.286/0.300 Vp-p (Chroma)
Component Video	1.0Vp-p (Y With Sync), ±350mV (Pb,Pr)

SDI Input Signal Formats	
SMPTE-425M-A/B	1080p (60/59.94/50/30/29.97/25/24/23.98/30sF/29.97sF/25sF/24sF/23.98sF) / 1080i (60/59.94/50)
SMPTE-274M	1080i (60 / 59.94 / 50) 1080p (30/29.97/25/24/24sF/23.98/23.98sF)
SMPTE-296M	720p (60/59.94/50)
SMPTE-260M	1035i (60/59.94)
SMPTE-125M	480i (59.94)
ITU-R BT.656	576i (50)

2K Format	2048 x 1080p (24/24sF/23.98/23.98sF)
Audio IN	Embedded Audio / Analog stereo (Phone Jack)
Audio OUT	Analog stereo (Phone Jack) / Internal Speaker (Mixed Mono)
Power	DC 24V (2.5A) / AC 100~240V (50~60Hz)
Power Consumption (Approx.)	60Watts
Operating Temperature	0°C to 40°C (32°F to 104°F)
Storage Temperature	-20°C to 60°C (-4°F to 140°F)
Accessory	AC Power Cord / Control Knob Cap / Stand

* Specifications may be changed without notice.

Main body Dimensions

- Main Body : 520 x 309 x 79 (mm) / 20.47 x 12.17 x 3.11 (inch)
- With stand : 567.2 x 340.8 x 142 (mm) / 22.33 x 13.41 x 5.59 (inch)
- Weight : 7.8kg / 17.16lbs

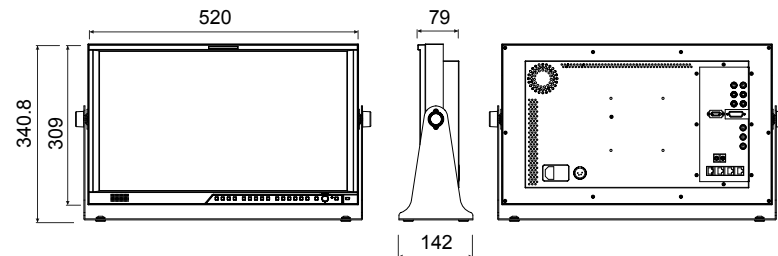

Optional Accessories



Product Highlights

- 21.5" 1920 x 1080 Native HD Resolution
- 3G-SDI Level A/B
- Audio Level Meter Display
- Blue Only
- Focus Assist
- H/V Delay
- Key lock
- Luma(Y) Zone Check
- Marker
- Time Code Display
- Various Scan modes
- Waveform/Vectorscope
- TVLogic Color Calibration Utility
- CC-608 LINE 21/ANC, CC-708
- Mono
- UMD
- Zoom
- OP47
- Range Error
- User Aspect
- OP42

Size	21.5"
Resolution	1920 x 1080 (16 : 9)
Pixel Pitch	0.2475mm
Color Depth	16.7M
Viewing Angle (Typ.)	178°(H) / 178°(V)
Luminance (Max.)	365cd/m ² (center)
Contrast Ratio	1000:1
Display Area	475(H) x 267(V) mm

SD/HD/3G-SDI Multi-Format Monitors

LVM-232W-A



Main body Dimensions

- Main Body : 552.5 x 354 x 66.1 (mm) / 21.75 x 13.93 x 2.6 (inch)
- With stand : 599.7 x 381.8 x 142 (mm) / 23.61 x 15.03 x 5.59 (inch)
- Weight : 6.9kg / 15.21lbs

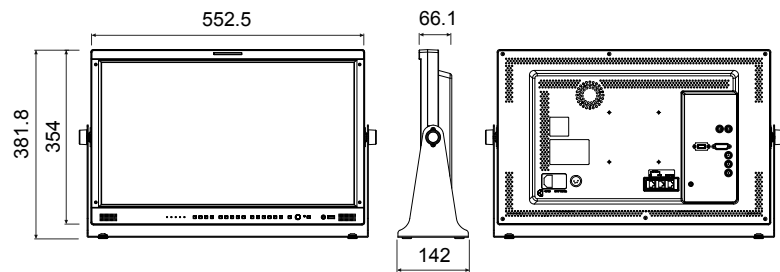

Optional Accessories



23" broadcast monitor with wide viewing angle and full HD resolution.

The LVM-232W-A is a versatile and cost-effective monitor that supports various video formats including 3G-SDI and professional features. Utilizing wide viewing angle IPS LCD panel combined with the TVLogic's proprietary video processing technology, the LVM-232W-A provides outstanding image monitoring quality with accurate colors and rich professional features.



Product Highlights

- 23" 1920 x 1080 (16:9) Resolution
- 3G-SDI Level A/B
- Audio Level Meter Display
- Blue Only
- Focus Assist
- H/V Delay
- Key lock
- Luma(Y) Zone Check
- Marker
- Mono
- Range Error
- Time Code Display
- Various Scan modes
- Waveform/Vectorscope
- TVLogic Color Calibration Utility
- CC-608 LINE 21/ANC, CC-708
- UMD • User Aspect
- Zoom

Size	23"
Resolution	1920 x 1080 (16:9)
Pixel Pitch	0.2652 mm
Color Depth	16.7M
Viewing Angle (Typ.)	178°(H) / 178°(V)
Luminance (Max.)	300 cd/m ² (center)
Contrast Ratio	1000:1
Display Area	509(H) x 286(V)

Input	
1 x BNC	Analog Input (CVBS)
2 x BNC	3G SDI A/B Channel Input
1 x HDMI	HDMI Input
1 x DVI - I	DVI Input
Output	
1 x BNC	Analog Output (CVBS)
1 x BNC	SDI A/B Selected Channel Output (Loop Through Out)
Input Signal	
Analog (Composite)	CVBS
3G-SDI	2.970Gb/s
HD-SDI	1.485Gb/s
SD-SDI	270Mb/s
DVI-Analog	640x480/720x400/800x600/1024x768/1280x768/1280x1024/1366x768/1920x1080
DVI-D (PC & HDMI)	640x480/720x400/800x600/1024x768/1280x768/1280x1024/1366x768/1920x1080/1080p(24/25/30/50/60)/1080i(50/60)/720p(50/60)/480i(60)/480p(60)/576i(50)/576p(50)
HDMI (PC & HDMI)	640x480/720x400/800x600/1024x768/1280x768/1280x1024/1366x768/1920x1080/1080p(24/25/30/50/60)/1080i(50/60)/720p(50/60)/480i(60)/480p(60)/576i(50)/576p(50)
Analog Input Spec	
CVBS	1.0Vp-p (With Sync) NTSC. PAL
SDI Input Signal Formats	
SMPTE-425M-A/B	1080p(60/59.94/50/30/29.97/25/24/23.98/30sF/29.97sF/25sF/24sF/23.98sF)1080i(60/59.94/50)
SMPTE-274M	1080i(60/59.94/50)/1080p(30/29.97/25/24/24sF/23.98/23.98sF)
SMPTE-296M	720p (60/59.94/50)
SMPTE-260M	1035i (60/59.94)
SMPTE-125M	480i (59.94)
ITU-R BT.656	576i (50)
Audio IN	
	Embedded Audio / Analog stereo (Phone Jack)
Audio OUT	
	Analog stereo (Phone Jack) / Internal Speaker (Stereo)
Power	
	DC 24V / DC 12V / AC 100 ~240V (50~ 60 Hz)
Power Consumption (Approx.)	
	60Watts
Operating Temperature	
	0°C to 40°C (32°F to 104°F)
Storage Temperature	
	-20°C to 60°C (-4°F to 140°F)
Accessory	
	AC Power Cord / Stand

* Specifications may be changed without notice.

SD/HD/3G-SDI Multi-Format Monitors

LVM-245W



Our Best 24" Quality Control Monitor

The LVM-245W is a broadcast monitor with high picture quality and professional features. Utilizing the same state-of-the-art TFT-LCD panel found in the XVM series, the LVM-245W provides a smooth color ramp with 10-bit color depth, high color purity and wide viewing angle.

Input support SD/HD/3G-SDI, DVI, HDMI, Component Video, S-Video and CVBS. And professional feature include Waveform / Vector Scope, Markers/Mattes, Timecode, Closed Captions, easy color calibration, and more.

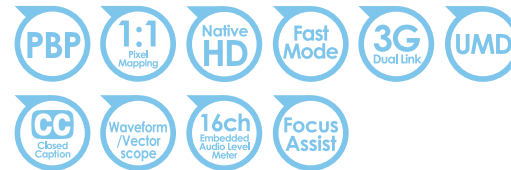

Main body Dimensions

- Main Body : 552.5 x 389 x 95 (mm) / 21.75 x 15.31 x 3.74 (inch)
- With stand : 586.1 x 416.8 x 150 (mm) / 23 x 16.4 x 5.9 (inch)
- Weight : 10.5kg / 23.1lbs

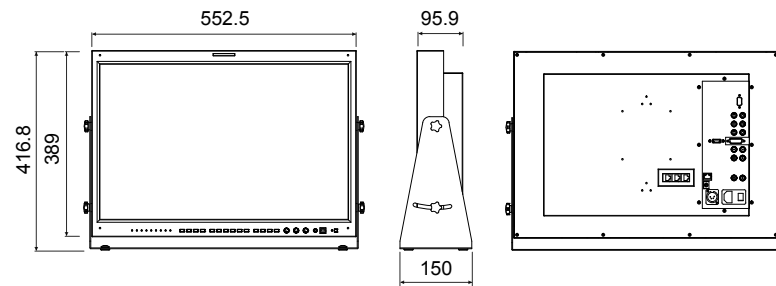

Optional Accessories



Product Highlights

- 24" 1920x1200 Native HD Resolution
- 1:1 Pixel Mapping Modes for SD/HD/FHD
- 3G-SDI Level A/B
- Audio Level Meter Display
- CC-608 LINE 21/ANC, CC-708, CC-KOR
- TVLogic Color Calibration Utility
- Blue Only
- H/V Delay
- Marker
- Range Error
- UMD
- Various Scan modes
- X3 Zoom(PBP)
- OP42, OP47
- Focus Assist
- Key lock
- Mono
- Time Code Display
- User Aspect
- Waveform/Vectorscope
- Zoom
- Luma(Y') Zone Check

Size	24"
Resolution	1920 x 1200 (16 : 10)
Pixel Pitch	0.270mm
Color Depth	1.07B
Viewing Angle (Typ.)	178°(H) / 178°(V)
Luminance (Max.)	250cd/m ² (center)
Contrast Ratio	1000:1
Display Area	518(H) x 324(V) mm

Input	
1 x DVI-I	DVI Input
1 x HDMI	HDMI(1.1Ver) Input
3 x BNC	CVBS / Component Input
2 x BNC	SDI A/B Channel Input
Output	
3 x BNC	Analog (Loop Through Out)
2 x BNC	SDI A/B Channel Output (Loop Through Out)
Input Signal	
Analog	CVBS / S-Video / Component
3G-SDI	2.970Gb/s
HD-SDI	1.485Gb/s
SD-SDI	270Mb/s
HDMI	480i/480p/576i/576p/720p/1080i/1080p/640x480/720x400/800x600/1024x768/1280x1024/1600x1200/1920x1200
DVI-Analog	640x480/720x400/800x600/1024x768/1280x1024/1600x1200/1920x1200
DVI-D (PC mode)	640x480/720x400/800x600/1024x768/1280x1024/1366x768/1600x1200/1920x1200
DVI-D (HDMI mode)	1080p (24/25/30/50/60)/1080i(50/60)/720p(50/60)/480i(60)/480p(60)/576i(50)/576p(50)
Analog Input Spec	
CVBS	1.0Vp-p (With Sync) NTSC. PAL
S-Video	1.0Vp-p (Y With Sync), 0.286/0.300 Vp-p(Chroma)
Component Video	1.0Vp-p (Y With Sync), ±350mV (Pb,Pr)
SDI Input Signal Formats	
SMPTTE-425M-A/B	1080p (60/59.94/50/30/29.97/25/24/23.98/30sF/29.97sF/25sF/24sF/23.98sF) / 1080i (60/59.94/50)
SMPTTE-372M (Dual Link)	Dual HD-SDI 1080p (60/59.94/50) YCbCr(4:2:2)
	Dual HD-SDI 1080i (60/59.94/50) YCbCr/RGB(4:4:4) 1080p (30/29.97/25/24/24sF/23.98/23.98sF)
SMPTTE-274M	1080i (60 / 59.94 / 50) 1080p (30/29.97/25/24/24sF/23.98/23.98sF)
SMPTTE-296M	720p (60/59.94/50)
SMPTE-260M	1035i (60/59.94)
SMPTE-125M	480i (59.94)
ITU-R BT.656	576i (50)
2K Format	2048 x 1080p (24/24sF/23.98/23.98sF)
Audio IN	Embedded Audio / Analog stereo (Phone Jack)
Audio OUT	Analog stereo (Phone Jack) / Internal Speaker (Stereo)
Power	DC 24V / AC 100~240V (50~60Hz)
Power Consumption (Approx.)	77Watts (Typ.)
Operating Temperature	0°C to 40°C (32°F to 104°F)
Storage Temperature	-20°C to 60°C (-4°F to 140°F)
Accessory	AC Power Cord / Stand

* Specifications may be changed without notice.

SD/HD/3G-SDI Multi-Format Monitors

LVM-246W



24" Full HD Display For Non-Critical Broadcast Monitoring Applications

The LVM-246W is our mid-level broadcast monitor with a wide viewing angle IPS LCD.

It supports SD/HD/3G-SDI, HDMI, DVI, Component Video, S-Video and CVBS signals and offers professional features such as Waveform / Vector Scope, Markers/Mattes, Timecode, Closed Caption and color calibration.

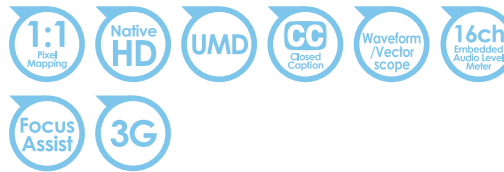

Product Highlights

- 24" 1920 x 1200 Native HD Resolution
- 3G-SDI Level A/B
- Audio Level Meter Display
- Blue Only
- Focus Assist
- H/V Delay
- Key lock
- Luma(Y) Zone Check
- Waveform/Vectorscope
- TVLogic Color Calibration Utility
- CC-608 LINE 21/ANC, CC-708
- Marker
 - Mono
- Range Error
 - Time Code Display
- UMD
 - User Aspect
- Zoom

Main body Dimensions

- Main Body : 552.5 x 389 x 95 (mm) / 21.75 x 15.31 x 3.74 (inch)
- With stand : 586.1 x 416.8 x 150 (mm) / 23 x 16.4 x 5.9 (inch)
- Weight : 10.4kg / 22.92lbs

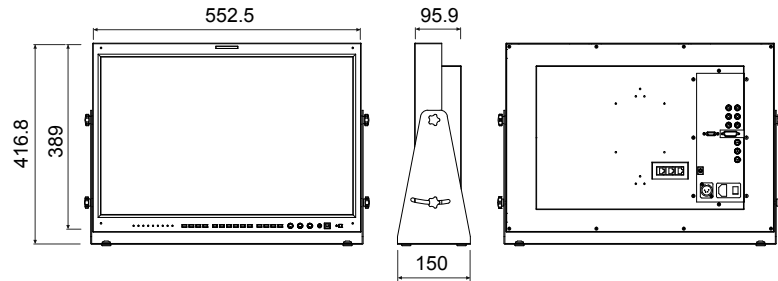

Optional Accessories



Size	24"
Resolution	1920 x 1200 (16 : 10)
Pixel Pitch	0.270mm
Color Depth	16.7M
Viewing Angle (Typ.)	178°(H) / 178°(V)
Luminance (Max.)	300cd/m ² (center)
Contrast Ratio	1000:1
Display Area	518(H) x 324(V) mm

Input	
1 x DVI-I	DVI Input
3 x BNC	CVBS / Component Input
2 x BNC	SDI A/B Channel Input
1 x HDMI	HDMI Input

Output	
3 x BNC	Analog (Loop Through Out)
1 x BNC	SDI A/B Selected Channel Output (Loop Through Out)

Input Signal	
Analog	CVBS / S-Video / Component
3G-SDI	2.970Gb/s
HD-SDI	1.485Gb/s
SD-SDI	270Mb/s
HDMI	480i/480p/576i/576p/720p/1080i/1080p/640x480/720x400/800x600/1024x768/1280x1024/1600x1200/1920x1200
DVI-Analog	640x480/720x400/800x600/1024x768/1280x768/1280x1024/1366x768
DVI-D (PC mode)	640x480/720x400/800x600/1024x768/1280x768/1280x1024
DVI-D (HDMI mode)	1080p (24/25/30/50/60)/1080i(50/60)/720p (50/60)/480i(60)/480p(60)/576i(50)/576p(50)

Analog Input Spec	
CVBS	1.0Vp-p (With Sync) NTSC. PAL
S-Video	1.0Vp-p (Y With Sync), 0.286/0.300 Vp-p (Chroma)
Component Video	1.0Vp-p (Y With Sync), ±350mV (Pb,Pr)

SDI Input Signal Formats	
SMPTE-274M	1080i (60 / 59.94 / 50)
	1080p (30/29.97/25/24/24sF/23.98/23.98sF)
SMPTE-296M	720p (60/59.94/50)
SMPTE-260M	1035i (60/59.94)
SMPTE-125M	480i (59.94)
ITU-R BT.656	576i (50)
2K Format	2048 x 1080p (24/24sF/23.98/23.98sF)
Audio IN	Embedded Audio / Analog stereo (Phone Jack)
Audio OUT	Analog stereo (Phone Jack) / Internal Speaker (Stereo)
Power	DC 24V / AC 100~240V (50~60Hz)
Power Consumption (Approx.)	77Watts
Operating Temperature	0°C to 40°C (32°F to 104°F)
Storage Temperature	-20°C to 60°C (-4°F to 140°F)
Accessory	AC Power Cord / Stand

* Specifications may be changed without notice.

SD/HD/3G-SDI Multi-Format Monitors

LVM-327W



32" 1920 x 1080 Native HD LCD Display

The LVM-327W utilizes a 10 bit 32" 1920 x 1080 Native Resolution LCD panel. This model accepts a wide range of input including 3G/Dual-Link and offers TVLogic's industry-leading scaling technology.

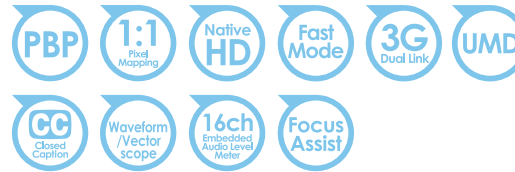

Product Highlights

- 32" 1920 x 1080 Native HD Resolution
- 1:1 Pixel Mapping Modes for SD/HD/FHD
- Blue Only
- H/V Delay
- Key lock
- Marker
- Mono
- Range Error
- Time Code Display
- UMD
- User Aspect
- Waveform/Vectorscope
- CC-608 LINE 21/ANC, CC-708, CC-KOR
- OP42
- OP47
- TVLogic Color Calibration Utility

Main body Dimensions

- Main Body : 769.4 x 485.1 x 102.1 (mm) / 30.29 x 19.09 x 4.01 (inch)
- With stand : 769.4 x 539.3 x 255 (mm) / 30.29 x 21.23 x 10.03 (inch)
- Weight : 22.6kg / 49.8lbs

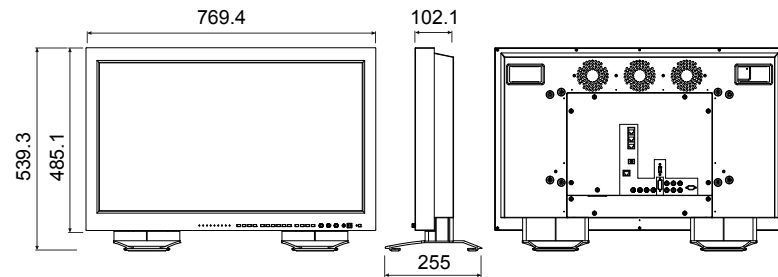

Optional Accessories



Size	32"
Resolution	1920 x 1080 (16 : 9)
Pixel Pitch	0.364mm
Color Depth	1.07B
Viewing Angle (Typ.)	178°(H) / 178°(V)
Luminance (Max.)	500cd/m ² (center)
Contrast Ratio	1300:1
Display Area	698(H) x 382(V) mm

Input	
1 x DVI-I	DVI Input
1 x HDMI	HDMI Input
3 x BNC	Analog Input
2 x BNC	SDI A/B Channel Input

Output	
3 x BNC	Analog Output
2 x BNC	SDI A/B Channel Output (Loop Through Out)

Input Signal	
Analog	CVBS / S-Video / Component Video
3G-SDI	2.970Gb/s
HD-SDI	1.485Gb/s
SD-SDI	270Mb/s
HDMI	480i/480p/576i/576p/720p/1080i/1080p/640x480/720x400/800x600/1024x768/1280x1024/1600x1200
DVI-Analog	640x480/720x400/800x600/1024x768/1280x1024/1600x1200/1920x1080
DVI-D (PC mode)	640x480/720x400/800x600/1024x768/1280x1024/1600x1200/1920x1080/1920x1200
DVI-D (HDMI mode)	1080p (24/25/30/50/60)/1080i(50/60)/720p(50/60)/480i(60)/480p(60)/576i(50)/576p(50)

Analog Input Spec	
CVBS	1.0Vp-p (With Sync) NTSC. PAL
S-Video	1.0Vp-p (Y With Sync), 0.286Vp-p(Chroma)
Component Video	1.0Vp-p (Y With Sync), 0.7Vp-p (Pb,Pr)

SDI Input Signal Formats	
SMPTE-425M-A/B	1080p (60/59.94/50/30/29.97/25/24/23.98/30sF/29.97sF/25sF/24sF/23.98sF) / 1080i (60/59.94/50)
SMPTE-372M (Dual Link)	Dual HD-SDI 1080p (60/59.94/50) YCbCr(4:2:2)
	Dual HD-SDI 1080i (60/59.94/50) YCbCr/RGB(4:4:4)
SMPTE-274M	1080i (60 / 59.94 / 50)
	1080p (30/29.97/25/24/24sF/23.98/23.98sF)
SMPTE-296M	720p (60/59.94/50)
SMPTE-260M	1035i (60/59.94)
SMPTE-125M	480i (59.94)
ITU-R BT.656	576i (50)
2K Format	2048 x 1080p (23.98p/psf, 24p/psf)
Audio IN	Embedded Audio / Analog stereo(Phone Jack)
Audio OUT	Analog stereo (Phone Jack)
Power	AC 100~240V (50~60Hz)
Power Consumption (Approx.)	145Watts (MAX)
Operating Temperature	0°C to 35°C (32°F to 95°F)
Storage Temperature	-20°C to 60°C (-4°F to 140°F)
Accessory	AC Power Cord / Stand

* Specifications may be changed without notice.

Studio Wall Monitors

SWM-171A *New!*



17" Studio Wall Monitor

The SWM series monitors are newly designed with a clean bezel with only a power button and a small indication lamp ideal for studio wall configuration

Along with the traditional interfaces of 3G-SDI, HDMI and DVI, an optical fiber interface has been added for added flexibility. Features include Markers/Mattes, Timecode, Audio Level Meters, various CCs and UMDs.



Product Highlights

- 16.5" 1920 x 1080 (16:9) Resolution
- 3G-SDI Level A/B
- Audio Level Meter Display
- Blue Only
- H/V Delay
- Marker
- Mono
- Time Code Display
- UMD
- User Aspect
- CC-608 LINE 21/ANC, CC-708, CC-KOR
- OP42
- OP47
- Network Control by Observer (Free PC Software)
- Auto Calibration

Main body Dimensions

- Main Body : 431 x 264 x 86.9 (mm) / 16.97 x 10.39 x 3.42 (inch)
- Weight : TBD

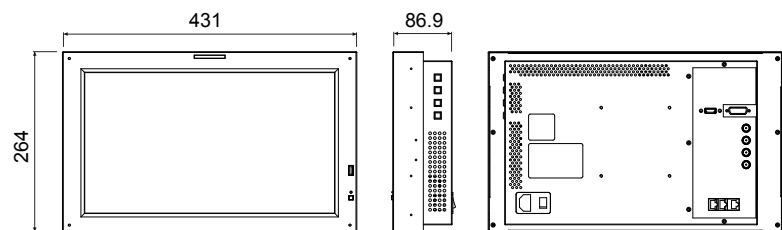

Optional Accessories



Size	16.5"
Resolution	1920 x 1080 (16 : 9)
Pixel Pitch	0.1905mm
Color Depth	1.07B
Viewing Angle (Typ.)	178°(H) / 178°(V)
Luminance (Max.)	450cd/m ²
Contrast Ratio	1400:1
Display Area	366(H) x 206(V) mm

Input	
1 x DVI-I	DVI Input
1xHDMI	HDMI Input
2xBNC	SDI A/B Channel Input
1xSFP Module	Optical Input(Option)
Output	
2xBNC	SDI A/B Channel (Active Through Out)
Input Signal	
3G SDI	2.970Gb/s
HD-SDI	1.485Gb/s
SD-SDI	270Mb/s
HDMI	480i / 480p / 576i / 576p / 720p / 1080i / 1080p / 640x480 / 720x400 / 800x600 / 1024x768 / 1280x1024 / 1600x1200
DVI-D (PC mode)	640x480/720x400/800x600/1024x768/1280x1024/1366x768/1600x1200/1920x1200
DVI-D (HDMI mode)	1080p(24/25/30/50/60)/1080i(50/60)/720p(50/60)/480i(60)/480p(60)/576i(50)/576p(50)
OPTICAL	2.970Gbps / 1.485Gbps / 270Mbps
SDI Input Signal Formats	
SMPTE-425M-A/B	1080i (60/59.94/50)
	1080p (60/59.94/50/30/29.97/25/24/23.98/30sF/29.97sF/25sF/24sF/23.98sF)
SMPTE-372M (Dual Link)	Dual HD-SDI YCbCr(4:2:2) 1080p (60/59.94/50)
	Dual HD-SDI YCbCr/RGB(4:4:4) 1080i (60/59.94/50) 1080p (30/29.97/25/24/24sF/23.98/23.98sF)
SMPTE-274M	1080i (60 / 59.94 / 50)
	1080p (30/29.97/25/24/24sF/23.98/23.98sF)
SMPTE-296M	720p (60/59.94/50)
SMPTE-260M	1035i (60/59.94)
SMPTE-125M	480i (59.94)
ITU-R BT.656	576i (50)
2K Format	2048 x 1080p (24/24sF/23.98/23.98sF)
Audio IN	-
Audio OUT	-
Power	AC 100~240V (50~60Hz)
Power Consumption (Approx.)	TBD
Operating Temperature	0°C to 40°C (32°F to 104°F)
Storage Temperature	-20°C to 60°C (-4°F to 140°F)
Accessory	AC Power Cord / USB Cover

* Specifications may be changed without notice.

Studio Wall Monitors

SWM-240A



Main body Dimensions

- Main Body : 552.5 x 389 x 95.8 (mm) / 21.75 x 15.31 x 3.77 (inch)
- Weight : 8.2kg / 18.04lbs

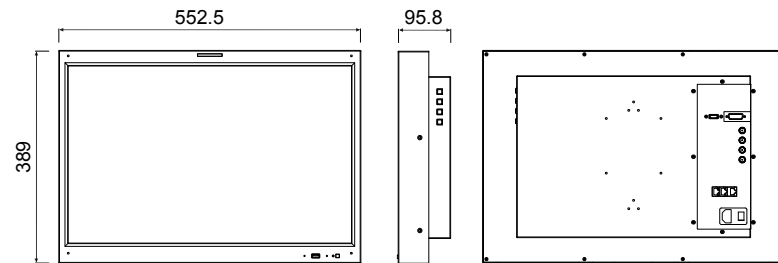

Optional Accessories



24" Studio Wall Monitor

The SWM series monitors are newly designed with a clean bezel with only a power button and a small indication lamp ideal for studio wall configuration

Along with the traditional interfaces of 3G-SDI, HDMI and DVI, an optical fiber interface has been added for added flexibility. Features include Markers/Mattes, Timecode, Audio Level Meters, various CCs and UMDs.



Product Highlights

- 24" 1920 x 1200 (16:10) Resolution
- 3G-SDI Level A/B
- Audio Level Meter Display
- Blue Only
- H/V Delay
- Marker
- Mono
- Time Code Display
- UMD
- User Aspect
- CC-608 LINE 21/ANC, CC-708, CC-KOR
- OP42
- OP47
- Network Control by Observer (Free PC Software)
- Auto Calibration

Size	24"
Resolution	1920 x 1200 (16 : 10)
Pixel Pitch	0.270mm
Color Depth	16.7M
Viewing Angle (Typ.)	178°(H) / 178°(V)
Luminance (Max.)	300cd/m ²
Contrast Ratio	1000:1
Display Area	518(H) x 324(V) mm

Input	
1 x DVI-I	DVI Input
1xHDMI	HDMI Input
2xBNC	SDI A/B Channel Input
1xSFP Module	Optical Input(Optional)
Output	
2xBNC	SDI A/B Channel (Loop Through Out)
Input Signal	
3G SDI	2.970Gb/s
HD-SDI	1.485Gb/s
SD-SDI	270Mb/s
HDMI	480i / 480p / 576i / 576p / 720p / 1080i / 1080p / 640x480 / 720x400 / 800x600 / 1024x768 / 1280x1024 / 1600x1200
DVI-D (PC mode)	640x480/720x400/800x600/1024x768/1280x1024/1366x768/1600x1200/1920x1200
DVI-D (HDMI mode)	1080p(24/25/30/50/60)/1080i(50/60)/720p(50/60)/480i(60)/480p(60)/576i(50)/576p(50)
OPTICAL	2.970Gbps / 1.485Gbps / 270Mbps
SDI Input Signal Formats	
SMPTE-425M-A/B	1080i (60/59.94/50)
	1080p (60/59.94/50/30/29.97/25/24/23.98/30sF/29.97sF/25sF/24sF/23.98sF)
SMPTE-372M (Dual Link)	Dual HD-SDI YCbCr(4:2:2) 1080p (60/59.94/50)
	Dual HD-SDI YCbCr/RGB(4:4:4) 1080i (60/59.94/50) 1080p (30/29.97/25/24/24sF/23.98/23.98sF)
SMPTE-274M	1080i (60 / 59.94 / 50)
	1080p (30/29.97/25/24/24sF/23.98/23.98sF)
SMPTE-296M	720p (60/59.94/50)
SMPTE-260M	1035i (60/59.94)
SMPTE-125M	480i (59.94)
ITU-R BT.656	576i (50)
2K Format	2048 x 1080p (24/24sF/23.98/23.98sF)
Audio IN	-
Audio OUT	-
Power	AC 100~240V (50~60Hz)
Power Consumption (Approx.)	73Watts(Max.)
Operating Temperature	0°C to 40°C (32°F to 104°F)
Storage Temperature	-20°C to 60°C (-4°F to 140°F)
Accessory	AC Power Cord / USB Cover

* Specifications may be changed without notice.

Studio Wall Monitors

SWM-320A



32" Studio Wall Monitor

The SWM series monitors are newly designed with a clean bezel with only a power button and a small indication lamp ideal for studio wall configuration

Along with the traditional interfaces of 3G-SDI, HDMI and DVI, an optical fiber interface has been added for added flexibility. Features include Markers/Mattes, Timecode, Audio Level Meters, various CCs and UMDs.



Product Highlights

- 32" 1920 x 1080 (16:9) Resolution
- 3G-SDI Level A/B
- Audio Level Meter Display
- Blue Only
- H/V Delay
- Marker
- Mono
- Time Code Display
- UMD
- User Aspect
- CC-608 LINE 21/ANC, CC-708, CC-KOR
- OP42
- OP47
- Network Control by Observer (Free PC Software)
- Auto Calibration

Main body Dimensions

- Main Body : 769.4 x 485.1 x 102.1 (mm) / 30.29 x 19.09 x 4.01 (inch)

- Weight : 18kg / 39.6lbs

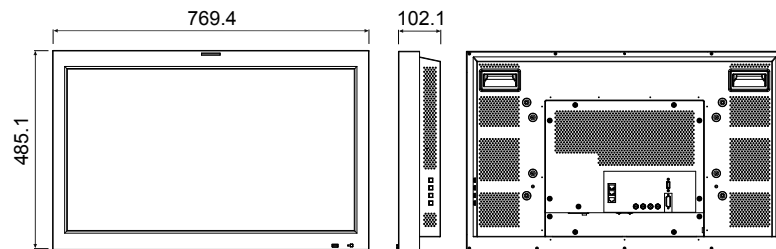

Optional Accessories



Size	32"
Resolution	1920 x 1080 (16 : 9)
Pixel Pitch	0.364mm
Color Depth	1.07B
Viewing Angle (Typ.)	178°(H) / 178°(V)
Luminance (Max.)	500cd/m ² (center)
Contrast Ratio	1300:1
Display Area	698(H) x 382(V) mm

Input	
1 x DVI-I	DVI Input
1xHDMI	HDMI Input
2xBNC	SDI A/B Channel Input
1xSFP Module	Optical Input(Option)
Output	
2xBNC	SDI A/B Channel (Loop Through Out)
Input Signal	
3G SDI	2.970Gb/s
HD-SDI	1.485Gb/s
SD-SDI	270Mb/s
HDMI	480i / 480p / 576i / 576p / 720p / 1080i / 1080p / 640x480 / 720x400 / 800x600 / 1024x768 / 1280x1024 / 1600x1200
DVI-D (PC mode)	640x480/720x400/800x600/1024x768/1280x1024/1366x768/1600x1200/1920x1200
DVI-D (HDMI mode)	1080p(24/25/30/50/60)/1080i(50/60)/720p(50/60)/480i(60)/480p(60)/576i(50)/576p(50)
OPTICAL	2.970Gbps / 1.485Gbps / 270Mbps
SDI Input Signal Formats	
SMPTE-425M-A/B	1080i (60/59.94/50)
	1080p (60/59.94/50/30/29.97/25/24/23.98/30sF/29.97sF/25sF/24sF/23.98sF)
SMPTE-372M (Dual Link)	Dual HD-SDI YCbCr(4:2:2) 1080p (60/59.94/50)
	Dual HD-SDI YCbCr/RGB(4:4:4) 1080i (60/59.94/50) 1080p (30/29.97/25/24/24sF/23.98/23.98sF)
SMPTE-274M	1080i (60 / 59.94 / 50)
	1080p (30/29.97/25/24/24sF/23.98/23.98sF)
SMPTE-296M	720p (60/59.94/50)
SMPTE-260M	1035i (60/59.94)
SMPTE-125M	480i (59.94)
ITU-R BT.656	576i (50)
2K Format	2048 x 1080p (24/24sF/23.98/23.98sF)
Audio IN	-
Audio OUT	-
Power	AC 100~240V (50~60Hz)
Power Consumption (Approx.)	192Watts(Max.)
Operating Temperature	0°C to 40°C (32°F to 104°F)
Storage Temperature	-20°C to 60°C (-4°F to 140°F)
Accessory	AC Power Cord / USB Cover

* Specifications may be changed without notice.

Studio Wall Monitors

SWM-420A



42" Studio Wall Monitor

The SWM series monitors are newly designed with a clean bezel with only a power button and a small indication lamp ideal for studio wall configuration

Along with the traditional interfaces of 3G-SDI, HDMI and DVI, an optical fiber interface has been added for added flexibility. Features include Markers/Mattes, Timecode, Audio Level Meters, various CCs and UMDs.



Product Highlights

- 42" 1920 x 1080 (16:9) Resolution
- 3G-SDI Level A/B
- Audio Level Meter Display
- Blue Only
- H/V Delay
- Marker
- Mono
- Time Code Display
- UMD
- User Aspect
- CC-608 LINE 21/ANC, CC-708, CC-KOR
- OP42
- OP47
- Network Control by Observer (Free PC Software)
- Auto Calibration

Input	
1 x DVI-I	DVI Input
1xHDMI	HDMI Input
2xBNC	SDI A/B Channel Input
1xSFP Module	Optical Input(Optional)

Output	
2xBNC	SDI A/B Channel (Loop Through Out)

Input Signal	
3G SDI	2.970Gb/s
HD-SDI	1.485Gb/s
SD-SDI	270Mb/s
HDMI	480i / 480p / 576i / 576p / 720p / 1080i / 1080p / 640x480 / 720x400 / 800x600 / 1024x768 / 1280x1024 / 1600x1200
DVI-D (PC mode)	640x480/720x400/800x600/1024x768/1280x1024/1366x768/1600x1200/1920x1200
DVI-D (HDMI mode)	1080p(24/25/30/50/60)/1080i(50/60)/720p(50/60)/480i(60)/480p(60)/576i(50)/576p(50)
OPTICAL	2.970Gbps / 1.485Gbps / 270Mbps

SDI Input Signal Formats

SMPTE-425M-A/B	1080i (60/59.94/50)	
	1080p (60/59.94/50/30/29.97/25/24/23.98/30sF/29.97sF/25sF/24sF/23.98sF)	
SMPTE-372M (Dual Link)	Dual HD-SDI YCbCr(4:2:2)	1080p (60/59.94/50)
	Dual HD-SDI YCbCr/RGB(4:4:4)	1080i (60/59.94/50) 1080p (30/29.97/25/24/24sF/23.98/23.98sF)
SMPTE-274M	1080i (60 / 59.94 / 50)	
	1080p (30/29.97/25/24/24sF/23.98/23.98sF)	
SMPTE-296M	720p (60/59.94/50)	
SMPTE-260M	1035i (60/59.94)	
SMPTE-125M	480i (59.94)	
ITU-R BT.656	576i (50)	
2K Format	2048 x 1080p (24/24sF/23.98/23.98sF)	

Audio IN	-
Audio OUT	-
Power	AC 100~240V (50~60Hz)
Power Consumption (Approx.)	120Watts(Max.)
Operating Temperature	0°C to 40°C (32°F to 104°F)
Storage Temperature	-20°C to 60°C (-4°F to 140°F)
Accessory	AC Power Cord / USB Cover

* Specifications may be changed without notice.

Main body Dimensions

- Main Body : 985 x 581 x 96.4 (mm) / 38.77 x 22.87 x 3.79 (inch)
- Weight : 28.95kg / 63.69lbs

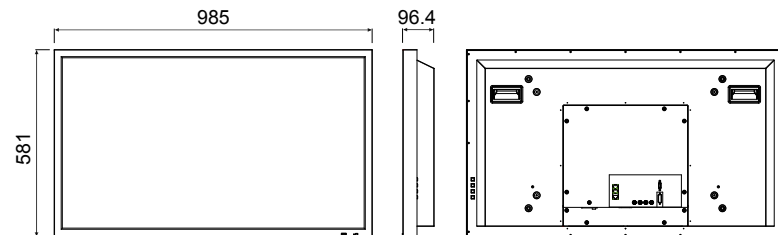

Optional Accessories



Size	42"
Resolution	1920 x 1080 (16 : 9)
Pixel Pitch	0.484mm
Color Depth	1.07B
Viewing Angle (Typ.)	178°(H) / 178°(V)
Luminance (Max.)	500cd/m ²
Contrast Ratio	4000:1
Display Area	930(H) x 523(V) mm

Studio Wall Monitors

SWM-460A



46" Studio Wall Monitor

The SWM series monitors are newly designed with a clean bezel with only a power button and a small indication lamp ideal for studio wall configuration

Along with the traditional interfaces of 3G-SDI, HDMI and DVI, an optical fiber interface has been added for added flexibility. Features include Markers/Mattes, Timecode, Audio Level Meters, various CCs and UMDs.



Product Highlights

- 46" 1920 x 1080 (16:9) Resolution
- 3G-SDI Level A/B
- Audio Level Meter Display
- Blue Only
- H/V Delay
- Marker
- Mono
- Time Code Display
- UMD
- User Aspect
- CC-608 LINE 21/ANC, CC-708, CC-KOR
- OP42
- OP47
- Network Control by Observer (Free PC Software)
- Auto Calibration

Main body Dimensions

- Main Body : 1070.6 x 630.5 x 100.6 (mm) / 42.14 x 24.82 x 3.96 (inch)
- Weight : 32.25kg / 70.95lbs

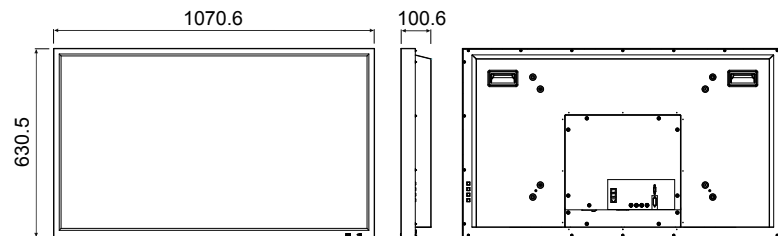

Optional Accessories



Size	46"
Resolution	1920 x 1080 (16 : 9)
Pixel Pitch	0.53mm
Color Depth	1.07B
Viewing Angle (Typ.)	178°(H) / 178°(V)
Luminance (Max.)	500cd/m ²
Contrast Ratio	4000:1
Display Area	1044(H) x 573(V) mm

Input	
1 x DVI-I	DVI Input
1xHDMI	HDMI Input
2xBNC	SDI A/B Channel Input
1xSFP Module	Optical Input(Optional)
Output	
2xBNC	SDI A/B Channel (Active Through Out)
Input Signal	
3G SDI	2.970Gb/s
HD-SDI	1.485Gb/s
SD-SDI	270Mb/s
HDMI	480i / 480p / 576i / 576p / 720p / 1080i / 1080p / 640x480 / 720x400 / 800x600 / 1024x768 / 1280x1024 / 1600x1200
DVI-D (PC mode)	640x480/720x400/800x600/1024x768/1280x1024/1366x768/1600x1200/1920x1200
DVI-D (HDMI mode)	1080p(24/25/30/50/60)/1080i(50/60)/720p(50/60)/480i(60)/480p(60)/576i(50)/576p(50)
OPTICAL	2.970Gbps / 1.485Gbps / 270Mbps
SDI Input Signal Formats	
SMPTE-425M-A/B	1080i (60/59.94/50)
	1080p (60/59.94/50/30/29.97/25/24/23.98/30sF/29.97sF/25sF/24sF/23.98sF)
SMPTE-372M (Dual Link)	Dual HD-SDI YCbCr(4:2:2) 1080p (60/59.94/50)
	Dual HD-SDI YCbCr/RGB(4:4:4) 1080i (60/59.94/50) 1080p (30/29.97/25/24/24sF/23.98/23.98sF)
SMPTE-274M	1080i (60 / 59.94 / 50) 1080p (30/29.97/25/24/24sF/23.98/23.98sF)
SMPTE-296M	720p (60/59.94/50)
SMPTE-260M	1035i (60/59.94)
SMPTE-125M	480i (59.94)
ITU-R BT.656	576i (50)
2K Format	2048 x 1080p (24/24sF/23.98/23.98sF)
Audio IN	
Audio OUT	-
Power	AC 100~240V (50~60Hz)
Power Consumption (Approx.)	96Watts(Max.)
Operating Temperature	0°C to 40°C (32°F to 104°F)
Storage Temperature	-20°C to 60°C (-4°F to 140°F)
Accessory	AC Power Cord / USB Cover

* Specifications may be changed without notice.

Studio Wall Monitors

SWM-550A



55" Studio Wall Monitor

The SWM series monitors are newly designed with a clean bezel with only a power button and a small indication lamp ideal for studio wall configuration

Along with the traditional interfaces of 3G-SDI, HDMI and DVI, an optical fiber interface has been added for added flexibility. Features include Markers/Mattes, Timecode, Audio Level Meters, various CCs and UMDs.



Product Highlights

- 55" 1920 x 1080 (16:9) Resolution
- 3G-SDI Level A/B
- Audio Level Meter Display
- Blue Only
- H/V Delay
- Marker
- Mono
- Time Code Display
- UMD
- User Aspect
- CC-608 LINE 21/ANC, CC-708, CC-KOR
- OP42
- OP47
- Network Control by Observer (Free PC Software)
- Auto Calibration

Input	
1 x DVI-I	DVI Input
1xHDMI	HDMI Input
2xBNC	SDI A/B Channel Input
1xSFP Module	Optical Input(Optional)

Output	
2xBNC	SDI A/B Channel (Loop Through Out)

Input Signal	
3G SDI	2.970Gb/s
HD-SDI	1.485Gb/s
SD-SDI	270Mb/s
HDMI	480i / 480p / 576i / 576p / 720p / 1080i / 1080p / 640x480 / 720x400 / 800x600 / 1024x768 / 1280x1024 / 1600x1200
DVI-D (PC mode)	640x480/720x400/800x600/1024x768/1280x1024/1366x768/1600x1200/1920x1200
DVI-D (HDMI mode)	1080p(24/25/30/50/60)/1080i(50/60)/720p(50/60)/480i(60)/480p(60)/576i(50)/576p(50)
OPTICAL	2.970Gbps / 1.485Gbps / 270Mbps

SDI Input Signal Formats

SMPTE-425M-A/B	1080i (60/59.94/50)
	1080p (60/59.94/50/30/29.97/25/24/23.98/30sF/29.97sF/25sF/24sF/23.98sF)
SMPTE-372M (Dual Link)	Dual HD-SDI YCbCr(4:2:2) 1080p (60/59.94/50)
	Dual HD-SDI YCbCr/RGB(4:4:4) 1080i (60/59.94/50) 1080p (30/29.97/25/24/24sF/23.98/23.98sF)
SMPTE-274M	1080i (60 / 59.94 / 50)
	1080p (30/29.97/25/24/24sF/23.98/23.98sF)
SMPTE-296M	720p (60/59.94/50)
SMPTE-260M	1035i (60/59.94)
SMPTE-125M	480i (59.94)
ITU-R BT.656	576i (50)
2K Format	2048 x 1080p (24/24sF/23.98/23.98sF)

Audio IN	-
Audio OUT	-
Power	AC 100~240V (50~60Hz)
Power Consumption (Approx.)	96Watts(Max.)
Operating Temperature	0°C to 40°C (32°F to 104°F)
Storage Temperature	-20°C to 60°C (-4°F to 140°F)
Accessory	AC Power Cord / USB Cover

* Specifications may be changed without notice.

Main body Dimensions

- Main Body : 1262.4 x 735 x 95.5 (mm) / 49.7 x 28.94 x 3.75 (inch)
- Weight : 40.9kg / 89.98lbs

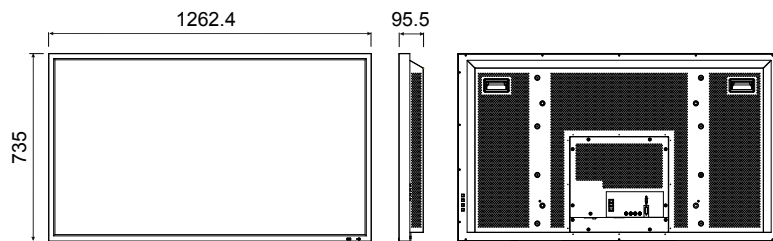

Optional Accessories



Size	54.6"
Resolution	1920 x 1080 (16 : 9)
Pixel Pitch	0.63mm
Color Depth	1.07B
Viewing Angle (Typ.)	178°(H) / 178°(V)
Luminance (Max.)	500cd / m ²
Contrast Ratio	4000:1
Display Area	1209(H) x 680(V) mm



Multi Viewer Monitors LHM-Series

TVLogic® Always ON-AIR

The LHM series offers a highly cost-effective solution for Multi-Viewer and Digital Information Display (DID) applications while providing the same great picture performance found in the LVM series monitors.

LHM-420A

The Best Monitor for Multi-Viewer System



Product Highlights

- 42" 1920x1080 Native HD Resolution with High Contrast 4000 : 1
- 1 X D-SUB
- 1 X DVI
- 1 X HDMI
- 1 X HD-SDI
- 2 X RJ45 Jack (RS485)
- HD-SDI / 15P D-SUB / DVI/ HDMI Inputs
- Video Mode/ Graphic Mode Support
- Supports TVLogic Color Calibration Utility for proper color alignment
- Matte Finish Panel
- Weight: 30kg / 66lbs

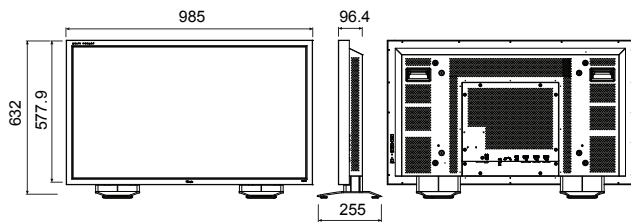

LHM-460A

The Excellent Monitoring Solution



Product Highlights

- 46" 1920x1080 Native HD Resolution with High Contrast 4000 : 1
- 1 X D-SUB
- 1 X DVI
- 1 X HDMI
- 1 X HD-SDI
- 2 X RJ45 Jack (RS485)
- HD-SDI / 15P D-SUB / DVI/ HDMI Inputs
- Video Mode/ Graphic Mode Support
- Supports TVLogic Color Calibration Utility for proper color alignment
- Matte Finish Panel
- Weight : 33kg / 72.6lbs

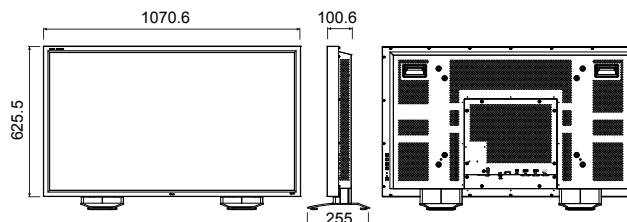

LHM-550A

New Standard of Multi-Viewer system



Product Highlights

- 54.6" 1920x1080 Native HD Resolution with High Contrast 4000 : 1
- 1 X D-SUB
- 1 X DVI
- 1 X HDMI
- 1 X HD-SDI
- 2 X RJ45 Jack (RS485)
- HD-SDI / 15P D-SUB / DVI/ HDMI Inputs
- Video Mode/ Graphic Mode Support
- Supports TVLogic Color Calibration Utility for proper color alignment
- Matte Finish Panel
- Weight : 42kg / 92.4lbs

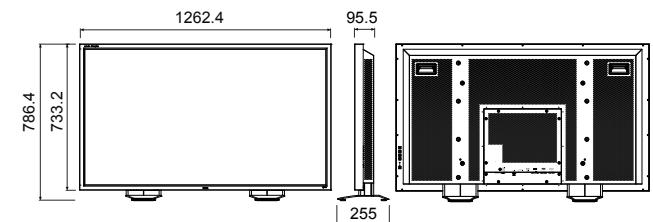

Precision Monitors

XVM-177A *New!*



Main body Dimensions

- Main Body : 445 x 264 x 78.4 (mm) / 17.52 x 10.39 x 3.09 (inch)
- With stand : 492.2 x 289 x 137.5 (mm) / 19.38 x 11.38 x 5.41 (inch)
- Weight : 6.88kg2 / 15.14lbs

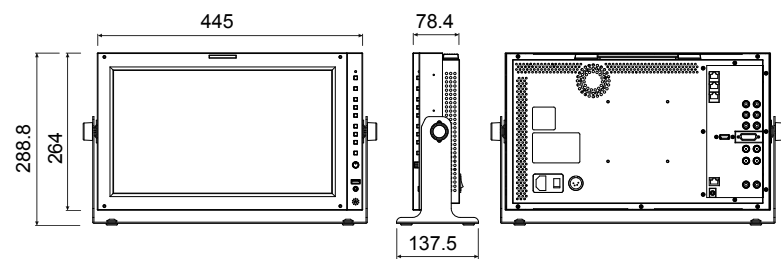

Optional Accessories



17" 10-bit Color Critical Monitor

The XVM-177A is a new 1920 x 1080 addition to XVM series. Designed for on-set and studio color-critical monitoring applications, TVLogic's advanced 12-bit video processing engine and precise color calibration technology combine with a latest-gen 1920x1080 native IPS LCD panel for unparalleled image quality

Features include: Focus Assist, Markers/Mattes, Waveform / Vectorscope, Timecode display, UMD, Closed Caption, Fast mode, multiple Colorspace presets with internal 3D LUT, Backlight and Gamma control, Import of 3rd party 3D LUTs and more.



Product Highlights

- 16.5" 1920 x 1080 (16:9) Resolution
- 1:1 Pixel Mapping Modes for SD/HD/FHD
- 3D LUT & Adjustable Gamma
- 3rd party 3D LUT import and export
- TVLogic Color Calibration Utility
- True 24p(48Hz) driving for Digital Cinema
- Audio Level Meter Display
- Waveform/Vectorscope
- Blue Only
- Key lock
- Mono
- Time Code Display
- X3 Zoom(PBP)
- Various Scan Modes
- Uniformity correction
- H/V Delay
- Marker
- Range Error
- UMD
- CC (608, 708, OP42, OP47)

Size	16.5"
Resolution	1920 x 1200 (16 : 10)
Pixel Pitch	0.191mm
Color Depth	1.07B (10bit)
Viewing Angle (Typ.)	178°(H) / 178°(V)
Luminance (Max.)	450cd/m ² (center)
Contrast Ratio	1400:1
Display Area	366(H)x206(V)mm

Input	
1 x DVI-I	DVI Input
3 x BNC	Analog Input
2 x BNC	SDI A/B Channel Input
1 x HDMI	HDMI Input
1 x BNC	External Sync. Input

Output	
3 x BNC	Analog (Loop Through Out)
2 x BNC	SDI A/B Channel Output (Loop Through Out)
1 x BNC	External Sync. Output

Input Signal	
Analog	Composite / S-Video / Component
3G-SDI	2.970Gb/s
HD-SDI	1.485Gb/s
SD-SDI	270Mb/s
DVI	VESA / IBM Modes
HDMI	480i/480p/720p/1080i / 1080p& VESA/IBM Modes

Analog Input Spec	
Composite	1.0Vpp (With Sync)
S-Video	1.0Vpp (Y With Sync), 0.286Vpp(C)
Component Video	1.0Vpp (Y With Sync), 0.7Vpp (Pb,Pr)

SDI Input Signal Formats		
SMPTE-425M-A/B	1080p (50/59.94/600)	
SMPTE-372M (Dual Link)	Dual HD-SDI YCbCr(4:2:2)	1080p (60/59.94/50)
	Dual HD-SDI YCbCr/ RGB(4:4:4)	1080i (60/59.94/50) 1080p/psf (30 / 29.97 / 25 / 24 / 23.98)

SMPTE-274M	1080i (60 / 59.94 / 50)	
	1080p (30/29.97/25/24/24sF/23.98/23.98sF)	

SMPTE-296M	720p (60/59.94/50)	
------------	--------------------	--

SMPTE-260M	1035i (60/59.94)	
------------	------------------	--

SMPTE-125M	480i (59.94)	
------------	--------------	--

ITU-R BT.656	576i (50)	
--------------	-----------	--

Audio IN	Analog Stereo	
----------	---------------	--

Audio OUT	Analog Stereo (Phone Jack)	
-----------	----------------------------	--

Power	DC 12V / AC 100~240V(50~60Hz)	
-------	-------------------------------	--

Power Consumption (Approx.)	TBD	
-----------------------------	-----	--

Operating Temperature	0°C to 45°C (32°F to 113°F)	
-----------------------	-----------------------------	--

Storage Temperature	-20°C to 60°C (-4°F to 140°F)	
---------------------	-------------------------------	--

Accessory	AC Power Cord / Stand	
-----------	-----------------------	--

* Specifications may be changed without notice.		
---	--	--

Precision Monitors

XVM-245W-N



Main body Dimensions

- Main Body : 552.5 x 389 x 95 (mm) / 21.75 x 15.31 x 3.74 (inch)
- With stand : 584 x 414 x 150 (mm) / 23 x 16.3 x 5.9 (inch)
- Weight : 11.05kg / 24.36lbs

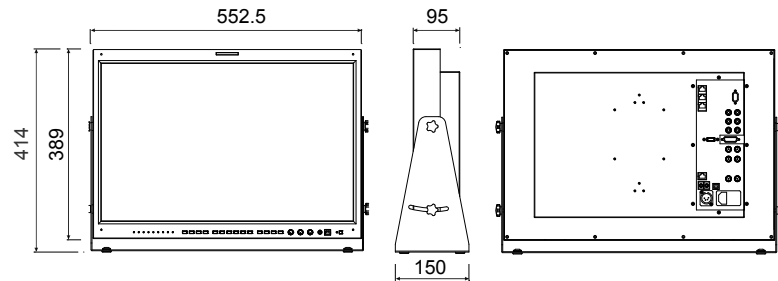

Optional Accessories



24" 10-bit Color Critical LCD Monitor

The XVM-245W-N utilizes a High-Purity RGB Matrix LED backlight array to reproduce the most accurate color possible on an LCD.

The XVM-245W-N features an integrated 3D LUT and supports import and export of popular color grading application LUT formats.

Additionally, support for TVLogic and SpectraCal calibration software is included.

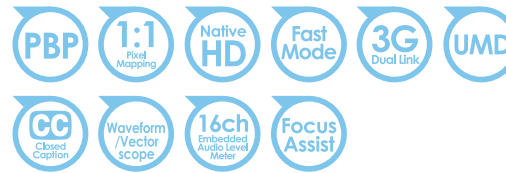

Product Highlights

- 24" 1920x1200 Native HD Resolution
- 1:1 Pixel Mapping Modes for SD/HD/FHD
- Audio Level Meter Display
- 3D LUT & Adjustable Gamma
- 3rd party 3D LUT import and export
- TVLogic Color Calibration Utility
- Uniformity correction
- CC-608 LINE 21/ANC, CC-708, CC-KOR
- Blue Only
- Key lock
- Mono
- Time Code Display
- User Aspect
- Waveform/Vectorscope
- OP42
- OP47
- 3G-SDI Level A/B
- H/V Delay
- Marker
- Range Error
- UMD
- Various Scan modes
- X3 Zoom(PBP)
- OP47

Size	24"
Resolution	1920 x 1200 (16 : 10)
Pixel Pitch	0.270mm
Color Depth	1.07B (True 10bit)
Viewing Angle (Typ.)	178°(H) / 178°(V)
Luminance (Max.)	250cd/m ² (center)
Contrast Ratio	1000:1
Display Area	518(H) x 324(V) mm

Input	
1 x DVI-I	DVI Input
3 x BNC	CVBS / Component Input
2 x BNC	SDI A/B Channel Input
1 x HDMI	HDMI Input
1 x BNC	External Sync. Input

Output	
3 x BNC	Analog (Loop Through Out)
2 x BNC	SDI A/B Channel Output (Loop Through Out)
1 x BNC	External Sync. Output

Input Signal	
Analog	CVBS / S-Video / Component Video
3G-SDI	2.970Gb/s
HD-SDI	1.485Gb/s
SD-SDI	270Mb/s
DVI	VESA / IBM Modes
HDMI	1080p (24/25/30/50/60)/1080i(50/60)/720p(50/60)/480i(60)/480p(60)/576i(50)/576p(50) & VESA/IBM Modes

Analog Input Spec	
CVBS	1.0Vp-p (With Sync) NTSC. PAL
S-Video	1.0Vp-p (Y With Sync), 0.286/0.300 Vp-p(Chroma)
Component Video	1.0Vp-p (Y With Sync), ±350mV (Pb,Pr)

SDI Input Signal Formats	
SMPTE-425M-A/B	1080p (60/59.94/50/30/29.97/25/24/23.98/30sF/29.97sF/25sF/24sF/23.98sF) / 1080i (60/59.94/50)
SMPTE-372M (Dual Link)	Dual HD-SDI 1080p (60/59.94/50) YCbCr(4:2:2)
	Dual HD-SDI 1080i (60/59.94/50) YCbCr/RGB(4:4:4) 1080p (30/29.97/25/24/24sF/23.98/23.98sF)
SMPTE-274M	1080i (60 / 59.94 / 50)
	1080p (30/29.97/25/24/24sF/23.98/23.98sF)
SMPTE-296M	720p (60/59.94/50)
SMPTE-260M	1035i (60/59.94)
SMPTE-125M	480i (59.94)
ITU-R BT.656	576i (50)
2K Format	2048 x 1080p (24/24sF/23.98/23.98sF)
Audio IN	Embedded Audio / Analog stereo (Phone Jack)
Audio OUT	Internal Speaker (Stereo) / Analog stereo (Phone Jack)
Power	DC 24V / AC 100~240V
Power Consumption (Approx.)	77Watts (Typ.)
Operating Temperature	0°C to 40°C (32°F to 104°F)
Storage Temperature	-20°C to 60°C (-4°F to 140°F)
Accessory	AC Power Cord / Stand

* Specifications may be changed without notice.

Precision Monitors

XVM-325W



32" 10-bit Color-Critical Monitor

The XVM-325W is designed to reproduce highly accurate colors and artifact free monitoring. TVLogic's advanced video processing engine and unique color calibration technology are combined with a true 10-bit IPS LCD panel with high performance wide-gamut EEFL backlight that reveals every detail with pristine accuracy.

Features include: Focus Assist, Markers/Mattes, Waveform/Vector Scope, Timecode display, UMD, Closed Captioning, Fast mode, Backlight and Gamma control, Import of 3rd party 3D LUTs and more.

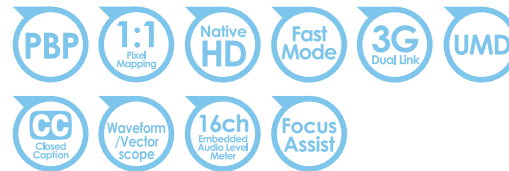

Product Highlights

- 32" 1920x1080 Native HD Resolution
- 1:1 Pixel Mapping Modes for SD/HD/FHD
- Audio Level Meter Display
- Various Scan modes
- Waveform/Vectorscope
- 3D LUT & Adjustable Gamma
- 3rd party 3D LUT import and export
- TVLogic Color Calibration Utility
- Uniformity correction
- CC-608 LINE 21/ANC, CC-708, CC-KOR
- Blue Only
- Key lock
- Mono
- Time Code Display
- 3G-SDI Level A/B
- X3 Zoom(PBP)
- OP47
- H/V Delay
- Marker
- Range Error
- UMD
- User Aspect
- OP42

Main body Dimensions

- Main Body : 769.4 x 485.1 x 102.1 (mm) / 30.29 x 19.1 x 4.01 (inch)
- With stand : 769.4 x 539.3 x 255 (mm) / 30.29 x 21.23 x 10 (inch)
- Weight : 22.25kg / 49.05lbs

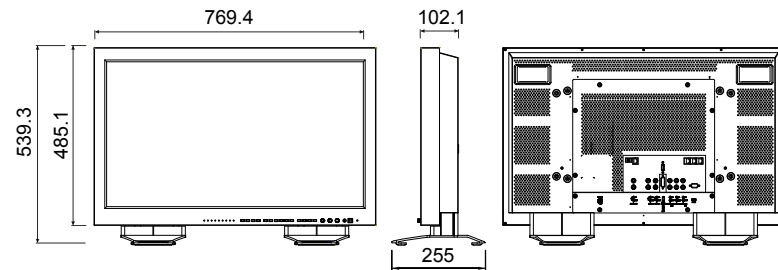

Optional Accessories



Size	32"
Resolution	1920 x 1080 (16 : 9)
Pixel Pitch	0.364mm
Color Depth	1.07B (True 10bit)
Viewing Angle (Typ.)	178°(H) / 178°(V)
Luminance (Max.)	500cd/m ² (center)
Contrast Ratio	1300:1
Display Area	698(H) x 382(V) mm

Input	
1 x DVI-I	DVI Input
1 x HDMI	HDMI(1.1Ver) Input
3 x BNC	CVBS / Component Input
2 x BNC	SDI A/B Channel Input
1 x BNC	Ext. Sync. Input
Output	
3 x BNC	Analog (Loop Through Out)
2 x BNC	SDI A/B Channel Output (Loop Through Out)
1 x BNC	Ext. Sync. out (Loop Through Out)
Input Signal	
Analog	CVBS / S-Video / Component
3G-SDI	2.970Gb/s
HD-SDI	1.485Gb/s
SD-SDI	270Mb/s
HDMI	1080p (24/25/30/50/60)/1080i(50/60)/720p(50/60)/480i(60)/480p(60)/576i(50)/576p(50)
DVI-Analog	640x480/720x400/800x600/1024x768/1280x1024/1600x1200
DVI-D (PC mode)	640x480/720x400/800x600/1024x768/1280x1024/1600x1200/1920x1080
DVI-D (HDMI mode)	1080p (24/25/30/50/60)/1080i(50/60)/720p(50/60)/480i(60)/480p(60)/576i(50)/576p(50)
Analog Input Spec	
CVBS	1.0Vp-p (With Sync) NTSC. PAL
S-Video	1.0Vp-p (Y With Sync), 0.286/0.300 Vp-p(Chroma)
Component Video	1.0Vp-p (Y With Sync), ±350mV (Pb,Pr)
SDI Input Signal Formats	
SMPTTE-425M-A/B	1080p (60/59.94/50/30/29.97/25/24/23.98/30sF/29.97sF/25sF/24sF/23.98sF) / 1080i (60/59.94/50)
SMPTTE-372M (Dual Link)	Dual HD-SDI YCbCr(4:2:2) 1080p (60/59.94/50)
	Dual HD-SDI YCbCr/RGB(4:4:4) 1080p (30/29.97/25/24/24sF/23.98/23.98sF)
SMPTTE-274M	1080i (60 / 59.94 / 50) 1080p (30/29.97/25/24/24sF/23.98/23.98sF)
SMPTTE-296M	720p (60/59.94/50)
SMPTTE-260M	1035i (60/59.94)
SMPTTE-125M	480i (59.94)
ITU-R BT.656	576i (50)
2K Format	2048 x 1080p (24/24sF/23.98/23.98sF)
Audio IN	Embedded Audio / Analog stereo (Phone Jack)
Audio OUT	Analog stereo (Phone Jack)
Power	AC 100~240V (50~60Hz)
Power Consumption (Approx.)	135Watts (Max.)
Operating Temperature	0°C to 40°C (32°F to 104°F)
Storage Temperature	-20°C to 60°C (-4°F to 140°F)
Accessory	AC Power Cord / Stand

* Specifications may be changed without notice.

AM-OLED High Performance Monitors

LEM-250A



24.5" 10-bit Reference OLED Monitor

TVLogic introduced the world's first AMOLED broadcast monitor, the LEM-150, in 2010. The 15inch HD production OLED monitor demonstrated the leap forward that the new display technology would enable for motion picture monitoring.

TVLogic's 2nd Gen AM-OLED monitor, the LEM-250A is a 24.5" native 1920 x 1080 resolution monitor utilizing the best OLED display available and equipped with all the features of TVLogic's XVM series reference monitors.

Combining TVLogic's most advanced video processing and color calibration technology, the LEM-250A is our pinnacle achievement in professional monitoring.

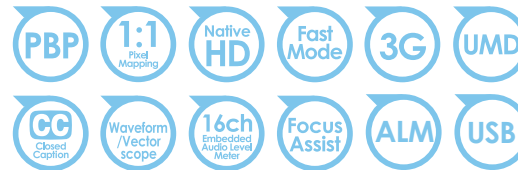

Product Highlights

- 24.5" 1920x1080 Native HD Resolution
- State-of-the-art AM-OLED Technology
- 1:1 Pixel Mapping Modes for SD/HD/FHD
- 3rd party 3D LUT import and export
- TVLogic Color Calibration Utility
- 3D LUT & Adjustable Gamma
- Audio Level Meter Display
- Blue Only
- H/V Delay
- Marker
- Range Error
- Time Code Display
- Various Scan modes
- Waveform/Vectorscope
- CC-608 ANC, CC-608 LINE 21, CC-708, CC-KOR
- Auto Calibration
- Luma('Y') Zone Check
- User Aspect
- Key lock
- Mono
- UMD
- X3 Zoom(PBP)
- OP42, OP47
- 3G-SDI Level A/B

Main body Dimensions

- Main Body : 578 x 392 x 98.6 (mm) / 22.76 x 15.43 x 3.88 (inch)
- With stand : 611.6 x 419.8 x 150 (mm) / 24.1 x 16.5 x 5.9 (inch)
- Weight : 12kg / 26.45lbs

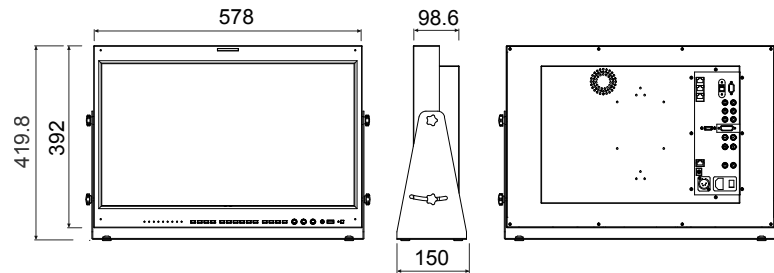

Optional Accessories



Size	24.5"
Resolution	1920 x 1080 (16 : 9)
Pixel Pitch	0.283mm
Color Depth	1.07B (True 10bit)
Viewing Angle (Typ.)	duv=0.008@30°
Luminance (Max.)	150cd/m ² (center)
Contrast Ratio	1200:1 (min), 5000:1 (dark)
Display Area	543 mm (H) x 306 mm (V)

Input	
1 x DVI-I	DVI Input
3 x BNC	CVBS / S-Video / Component / RGB(VGA)
2 x BNC	SDI A/B Channel Input
1 x HDMI	HDMI Input
1 x BNC	EXT SYNC INPUT

Output	
3 x BNC	CVBS / S-Video / Component
2 x BNC	SDI A/B Channel (Loop Through Out)
1 x BNC	EXT SYNC OUT(Loop Through Out)

Input Signal	
Analog(Composite)	CVBS / S-Video / Component
3G-SDI	2.970Gb/s
HD-SDI	1.485Gb/s
SD-SDI	270Mb/s
DVI	640x480/720x400/800x600/1024x768/1280x768/1280x1024/1366x768
HDMI (PC & HDMI mode)	1080p (23.98/24/25/30/50/59.94/60)/1080i(50/59.94/60)/720p(50/60)/480i(60)/480p(60)/576i(50)/576p(50)/640x480/720x400/800x600/1024x768/1280x768/1280x1024/1366x768

SDI Input Signal Formats	
SMPTE-425M-A/B	1080p(60/59.94/50/30/29.97/25/24/23.98/30sF/29.97sF/25sF/24sF/23.98sF), 1080i(60/59.94/50)
SMPTE-327M(Dual Link)	Dual HD-SDI YCbCr (4:2:2), 1080p (60/59.94/50), Dual HD-SDI YCbCr/RGB (4:2:2), 1080i (60/59.94/50), 1080p (30/29.97/25/24/24sF/23.98/23.98sF)
SMPTE-274M	1080i (60 / 59.94 / 50) 1080p (30/29.97/25/24/24sF/23.98/23.98sF)
SMPTE-296M	720p (60/59.94/50)
SMPTE-260M	1035i (60/59.94)
SMPTE-125M	480i (59.94)
ITU-R BT.656	576i (50)
2K Format	2048 x 1080p (24/24sF/23.98/23.98sF)
Audio IN	Embedded Audio / Analog stereo (Phone Jack)
Audio OUT	Analog stereo (Phone Jack) / Internal Speaker (Mixed Mono)
Power	DC 12/24V / AC 100~240V
Power Consumption (Approx.)	83 Watts(Typ.)
Operating Temperature	0°C to 45°C (32°F to 113°F)
Storage Temperature	-20°C to 60°C (-4°F to 140°F)
Accessory	AC Power Cord / Stand

* Specifications may be changed without notice.

12G / FHD Display

LUM-171G (12G / 4K) *New!*



17" 1920x1080 with up to 12G 4K input

The new LUM-171G monitor supports 3G/6G/12G-SDI input - 2x3G-SDI & 2x12G-SDI. The LUM-170G combines a native 1920 x 1080 IPS LCD with SD/HD/UHD/4K input support for the most versatile monitoring and field production applications



Product Highlights

- Practical hybrid of FHD panel + 4K Interface
- 16.5", 1920x1080 Resolution (16:9)
- Luminance up to 450cd/m²
- High Contrast Ratio of 1400:1
- Wide Viewing Angle
- 4K / UHD Interface
 - 2x12G-SDI & 2x3G-SDI in
 - 4xSDI out (Loop Through Out)
 - 1xHDMI in (HDMI 2.0)
- TVLogic Color Calibration Utility
- Matte Finish Panel
- True 24p(48Hz) driving for Digital Cinema
- 1:1 Pixel Mapping Modes for SD/HD/FHD
- Blue Only
- H/V Delay
- Audio Level Meter
- Marker
- Mono
- Time Code Display
- Focus Assist

Input	
4 x BNC	12G-SDI A/B Channel Input, 3G-SDI C/D Channel Input
1 x HDMI	HDMI Input (HDMI 2.0)
Output	
4 x BNC	12G-SDI A/B, 3G-SDI C/D Channel (Loop Through Out)
Input Signal	
12G-SDI	12Gb/s
6G-SDI	6Gb/s
3G-SDI	2.970Gb/s
HD-SDI	1.485Gb/s
HDMI	480p / 720p / 1080p / 2160p
SDI Input Signal Formats	
SMPTE-425M-A/B	1080p (50/59.94/60)
SMPTE-274M	1080p (23.98/24/25/29.97/30p/psF)
SMPTE-296M	720p (60/59.94/50)
SMPTE ST 2036-1:2009	3840x2160(23.98/24/25/29.97/30/50/59.94/60p)
SMPTE ST 2048-1:2011	2048x1080(23.98/24/25/29.97/30p/psf, 47.95/48/50/59.94/60p)
SMPTE ST 2081	3840x2160 (30/25/24p)
SMPTE ST 2082	3840x2160 (60/50/30/25/24p)
Audio IN	
Audio IN	Analog Stereo
Audio OUT	
Audio OUT	Analog Stereo (Phone Jack)
Power	
Power	DC 12V / AC 100~240V(50~60Hz)
Power Consumption (Approx.)	
Power Consumption (Approx.)	TBD
Operating Temperature	
Operating Temperature	0°C to 35°C (32°F to 95°F)
Storage Temperature	
Storage Temperature	-20°C to 60°C (-4°F to 140°F)
Accessory	
Accessory	AC Power Cord / Stand

* Specifications may be changed without notice.

Main body Dimensions

- Main Body : 445 x 264 x 78.4 (mm) / 17.52 x 10.39 x 3.09 (inch)
- With stand : 492.2 x 288.8 x 137.5 (mm) / 19.38 x 11.37 x 5.41 (inch)
- Weight : TBD

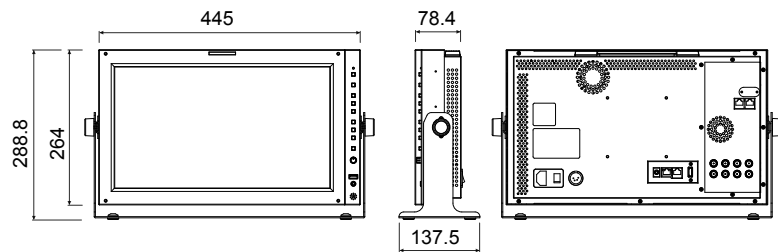

Optional Accessories



Size	16.5"
Resolution	1920X1080(16:9)
Pixel Pitch	0.1905mm
Color Depth	1.07B (10bit)
Viewing Angle (Typ.)	178°(H)/178°(V)
Luminance (Max.)	450cd/m ²
Contrast Ratio	1400:1
Display Area	366(H)x206(V)mm

12G / 4K Display

LUM-240G (12G/4K) *New!*



Main body Dimensions

- Main Body : 552 x 360 x 98.5 (mm) / 21.73 x 14.17 x 3.88 (inch)
- With stand : 586 x 388 x 150 (mm) / 23.07 x 15.27 x 5.9 (inch)
- Weight : TBD

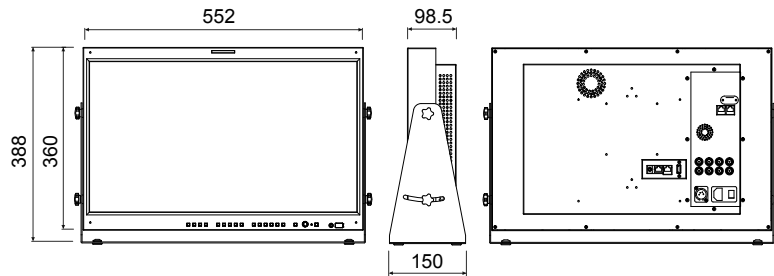

12G-SDI Single Link 4K

The LUM-240G is a 24" 4K(3840x2160) monitor with 12G-SDI interface - 2x3G-SDI & 2x12G-SDI. The LUM-240G supports various video formats including 12G/ 3G/ HD-SDI and HDMI 2.0. The LUM-240G provides wide color gamut up to DCI-P3 and includes 3D LUT support and a full feature set.



Product Highlights

- 23.8", True UHD Resolution (3840x2160)
- Color gamut covers up to DCI-P3
- High Contrast Ratio of 1000:1
- 1.07 Billion Colors (10bit)
- Wide Viewing Angle
- 4K / UHD Interface
 - 2x12G-SDI & 2x3G-SDI in
 - 4xSDI out (Loop Through Out)
 - 1xHDMI in (HDMI 2.0)
- TVLogic Color Calibration Utility
- Matte Finish Panel
- 1:1 Pixel Mapping Modes for SD/HD/FHD
- Time Code Display
- Focus Assist
- Audio Level Meter
- Blue Only
- Marker
- 3D LUT
- H/V/Meter
- Mono

Size	23.8"
Resolution	3840 x 2160 (17:9)
Pixel Pitch	0.137mm
Color Depth	1.07B (10bit)
Viewing Angle (Typ.)	178°(H)/178°(V)
Luminance (Max.)	350cd/m ²
Contrast Ratio	1000:1
Display Area	527(H)X296(V)mm

Input	
4 x BNC	12G-SDI A/B Channel Input, 3G-SDI C/D Channel Input
1 x HDMI	HDMI Input (HDMI 2.0)
Output	
4 x BNC	12G-SDI A/B, 3G-SDI C/D Channel (Loop Through Out)

Input Signal	
12G-SDI	12Gb/s
6G-SDI	6Gb/s
3G-SDI	2.970Gb/s
HD-SDI	1.485Gb/s
HDMI	480p / 720p / 1080p / 2160p

SDI Input Signal Formats	
SMPTE-425M-A/B	1080p (50/59.94/60)
SMPTE-274M	1080p (23.98/24/25/29.97/30p/psF)
SMPTE-296M	720p (60/59.94/50)
SMPTE ST 2036-1:2009	3840x2160(23.98/24/25/29.97/30/50/59.94/60p)
SMPTE ST 2048-1:2011	2048x1080(23.98/24/25/29.97/30p/psf, 47.95/48/50/59.94/60p)
SMPTE ST 2081	3840x2160 (30/25/24p)
SMPTE ST 2082	3840x2160 (60/50/30/25/24p)
Audio IN	
Audio IN	Analog Stereo
Audio OUT	
Audio OUT	Analog Stereo (Phone Jack)
Power	
Power	DC 24V / AC 100~240V(50~60Hz)
Power Consumption (Approx.)	
Power Consumption (Approx.)	115Watts(Max.)
Operating Temperature	
Operating Temperature	0°C to 35°C (32°F to 95°F)
Storage Temperature	
Storage Temperature	-20°C to 60°C (-4°F to 140°F)
Accessory	
Accessory	AC Power Cord / Stand

* Specifications may be changed without notice.

Optional Accessories



12G / 4K Display LUM-310A (4K)

12G/4K | 38



Main body Dimensions

- Main Body : 759.8 x 448.5 x 146.3 (mm) / 29.91 x 17.66 x 5.76 (inch)
- With stand : 759.8 x 501.5 x 255 (mm) / 29.91 x 19.74 x 10 (inch)
- Weight : 24.8kg / 54.67lbs

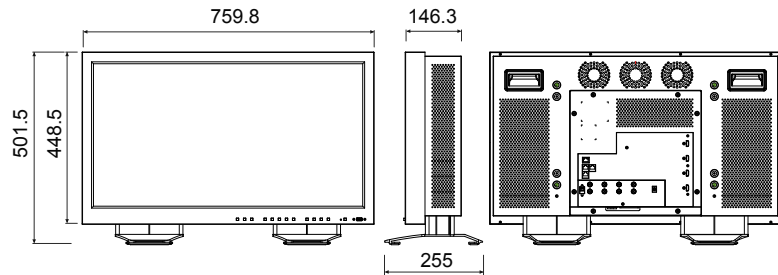

31" DCI-P3 4K Reference Monitor

UHD/4K monitor with a 31" native 4K (4096x2160) resolution, true 10-bit driver and DCI-P3 color gamut support. Accepts quad 3G-SDI and HDMI 1.4 inputs.



Product Highlights

- 31" 4096 x 2160 Resolution
- Matte Finish Panel
- True 4K Resolution
- True DCI color gamut
- True 24p(48Hz) driving for Digital Cinema
- 1:1 Pixel Mapping Modes for SD/HD/FHD
- Blue Only
- H/V Delay
- Marker
- Mono
- TVLogic Color Calibration Utility
- Single Mode (HD & FHD upscale to 3840*2160)

Size	31.1"
Resolution	4096 x 2160 (17:9)
Pixel Pitch	0.1704mm
Color Depth	1.07B (True 10bit)
Viewing Angle (Typ.)	178°(H) / 178°(V)
Luminance (Max.)	500cd/m ² (center)
Contrast Ratio	1450:1
Display Area	698(H) x 368(V) mm

Optional Accessories



TVLogic® Always ON-AIR

Input	
4 x BNC	3G-SDI A/B/C/D Channel Input
4 x HDMI	HDMI A/B/C/D Channel Input (HDMI 1.4)
Output	
4 x BNC	3G-SDI A/B/C/D Channel Output (Loop Through Out)
Input Signal	
3G-SDI	2.970Gb/s
HD-SDI	1.485Gb/s
HDMI	480p / 720p / 1080p / 2160p
SDI Input Signal Formats	
SMPTE-425M-A/B	1080p (60/59.94/50/30/29.97/25/24/23.98/30sF/29.97sF/25sF/24sF/23.98sF)
SMPTE-274M	1080p (30/29.97/25/24/24sF/23.98/23.98sF)
SMPTE-296M	720p (60/59.94/50)
SMPTE ST 2036-1:2009	3840x2160(23.98/24/25/29.97/30/50/59.94/60p)
SMPTE ST 2048-1:2011	2048x1080(23.98/24/25/29.97/30p/psf, 47.95/48/50/59.94/60p)
Audio Out	
Audio Out	Analog stereo (Phone Jack)
Power	
Power	DC 24V / AC 100~240V (50~60Hz)
Power Consumption (Approx.)	
Power Consumption (Approx.)	199 Watts(Max)
Operating Temperature	
Operating Temperature	0°C to 40°C (32°F to 104°F)
Storage Temperature	
Storage Temperature	-20°C to 50°C (-4°F to 122°F)
Accessory	
Accessory	AC Power Cord / Stand

*Support Resolution and Frame Rate

Input	Resolution / Frame Rate	Color / Bit Depth
HD-SDI Quad link (4K)	3840x2160 (24/25/30p)	YCbCr 4:2:2 10bit
	4096x2160 (24/25/30p)	YCbCr 4:4:4 10/12bit RGB 4:4:4 10/12bit
3G-SDI Quad link(4K)	3840x2160 (23.98/24/25/29.97/30p/Psf)	YCbCr 4:2:2 10bit
	4096x2160 (23.98/24/25/29.97/30p/Psf)	YCbCr 4:4:4 10/12bit RGB 4:4:4 10/12bit
3G-SDI 2-Sample Interleave Dual link(4K)	3840x2160 (50/59.94/60p)	YCbCr 4:2:2 10bit
	4096x2160 (47.95/48/50/59.94/60p)	
3G-SDI 2-Sample Interleave Quad link(4K)	3840x2160 (23.98/24/25/29.97/30p)	YCbCr 4:2:2 10bit
	4096x2160 (23.98/24/25/29.97/30p)	YCbCr 4:4:4 10/12bit RGB 4:4:4 10/12bit
3G-SDI 2-Sample Interleave Quad link(4K)	3840x2160 (50/59.94/60p)	YCbCr 4:2:2 10bit
	4096x2160 (47.95/48/50/59.94/60p)	

* Specifications may be changed without notice.

* NOTE : Please refer to the user manual for the supporting video formats.

Optional Accessories

	Acrylic Protector	Acrylic ND Filter	Rack Mount Kit (Dual, Single)	Camera Mount Ball Head	V-Mount / Gold Mount	Battery Bracket / D-Tap Cable	External Tally	Sun-Hood	Carrying Case	HDMI Bracket	SFP Module
VFM-056WP	●			●	● (V)	● (B, D)		●	●	●	
VFM-058W	● Included Free			●	● (V)	● (B, D)		●	●	●	
RKM-535A											
RKM-443A											
RKM-356A											
RKM-270A											
RKM-290A											
LVM-070C	●		● (D, S)	●	● (V, G)	● (D)	●	●	●	●	
LVM-074W	●		● (D, S)	●	● (V, G)	● (D)	●	●	●	●	
LVM-075A	● Included Free		● (D, S)	●	● (V, G)	● (D)	●	●	●	●	
SRM-074W -N	●		● (D, S)	●	● (V, G)	● (D)	●	●	●	●	
LVM-095W-N	●		● (D, S)	●				●	●	●	
LVM-171A		●	● (S)		● (V, G)			●	●		
LVM-182W-A		●	● (S)		● (V)				●		
LVM-212W			● (S)						●		
LVM-232W-A		●	● (S)		● (V)				●		
LVM-245W		●	● (S)						●		
LVM-246W		●	● (S)						●		
LVM-327W									●		
SWM-171A		●	● (S)								●
SWM-240A		●	● (S)								●
SWM-320A											●
SWM-420A									●		●
SWM-460A									●		●
SWM-550A									●		●
LHM-420A									●		
LHM-460A									●		
LHM-550A									●		
XVM-177A			● (S)						●		
XVM-245W-N			● (S)						●		
XVM-325W									●		
LEM-250A	●		● (S)		● (V, G)				●		
LUM-171G		●	● (S)		● (V, G)			●	●		
LUM-240G		●	● (S)		● (V, G)				●		
LUM-310A									●		
LUM-550W									●		



TVLogic is a broadcast monitor brand of Seven Star Works.

12F, ACE HIGH-END TOWER 8, 84, Gasan digital 1-ro,
Geumcheon-gu, Seoul 153-797, Korea

Tel : +82-70-8668-6611, Fax : +82-2-6123-3201

E-mail : sales@tvlogic.co.kr / support@tvlogic.co.kr

www.tvlogic.tv

